

DALI MSensor 5DPI 14

Multi-sensor for DALI system



DALI MSensor 5DPI 14f



DALI MSensor 5DPI 14f black



DALI MSensor 5DPI 14rc

Product description

- _ Component of the comfortDIM system (DALI standalone)
- _ With ambient light dependent control and presence detection
- _ Multiple DALI MSensors possible in a group
- _ Can be remote controlled
- _ Lighting control and presence detection can be deactivated
- _ Individual adjustment of the parameters with configuration software
- _ Multi-master compatible: Multiple control modules are possible in a DALI system
- _ Power supply via DALI line
- _ 5 years guarantee (conditions at <https://www.tridonic.com/en/int/services/manufacturer-guarantee-conditions>)

Housing properties

- _ Casing: polycarbonate, black or white
- _ Type of protection IP20

Website

<http://www.tridonic.com/28000935>



DALI MSensor 5DPI 14

Multi-sensor for DALI system

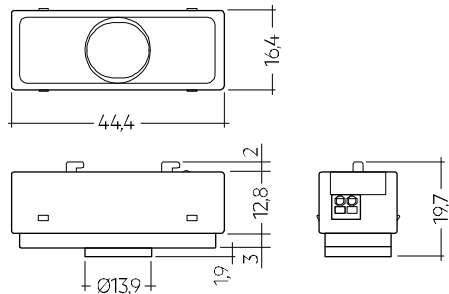

DALI MSensor 5DPI 14f + DALI MSensor 5DPI 14f black

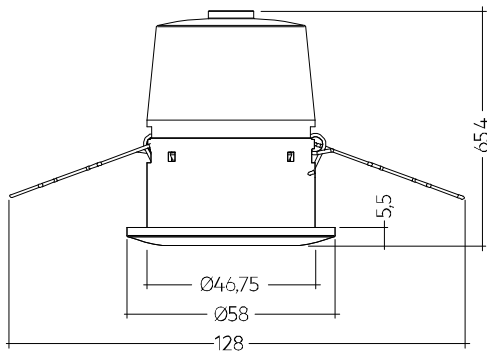

DALI MSensor 5DPI 14rc

Ordering data

Type	Article number	Suitable for	Packaging, carton	Weight per pc.
MSensor 5DPI 14f Luminaire installation	28000935	Luminaire installation	40 pc(s).	0.028 kg
MSensor 5DPI 14f black Luminaire installation	28001697	Luminaire installation	40 pc(s).	0.028 kg
MSensor 5DPI 14rc Ceiling installation	28000936	Ceiling installation	63 pc(s).	0.028 kg

Technical data

Sensor type	PIR sensor
Supply via	DALI cable
Current draw	6 mA from DALI
Operating temperature	0 ... +50 °C
Storage temperature ts	-25 ... +55 °C
Type of protection	IP20
Guarantee (conditions at www.tridonic.com)	5 Year(s)

Approval marks



Standards

EN 61547, EN 61347-1, EN 61347-2-11, EN 55015, EN 62386-101, EN 62386-102

Specific technical data

Type	Detection					
	Ø of detection range, mounted at a height of 2,5 m	Swivel design	Detection angle	Light measurement at the sensor head ^①	Infra-red control range	
MSensor 5DPI 14f	4.5 m	No	84°	10 – 650 lx	5 m	
MSensor 5DPI 14f black	4.5 m	No	84°	10 – 650 lx	5 m	
MSensor 5DPI 14rc	4.5 m	No	84°	10 – 650 lx	5 m	

① The measured value at the sensor head corresponds to approx. 15 to 2,000 lux on the surface measured.

REMOTECONTROL IR6

Accessory



Product description

- _ Optional infra-red remote control
- _ Switching on and off (On/Off button)
- _ Dimming (Up/Down button)
- _ Activation of automatic lighting control (Automatic button)
- _ Setting the threshold control point (Set button)
- _ IR range up to 20 m

Website

<http://www.tridonic.com/28000647>



Ordering data

Type	Article number	Dimensions L x W x H	Packaging, carton	Weight per pc.
REMOTECONTROL IR6	28000647	86.5 x 40.5 x 7.2 mm	500 pc(s).	0.019 kg

5DPI 14f Mounting Kit

Accessory



Product description

- _ Mounting frame for attaching all 5DP 14f sensor directly to the luminaire housing
- _ Optional shutter to prevent presence detection in a specific direction (for PIR sensors)
- _ Glow wire test with 750 °C according to EN 61347-1

Website

<http://www.tridonic.com/28001558>



Ordering data

Type	Article number	Packaging, carton	Weight per pc.
5DPI 14f mounting kit	28001558	100 pc(s).	0.004 kg
5DPI 14f mounting kit black	28001575	100 pc(s).	0.004 kg

ACU Sensor Housing 14rs IP20

Accessory



Product description

- _ Mounting frame for wired 5DP 14f sensors allowing direct mounting to the ceiling
- _ Easy „click in“ installation of the sensor
- _ IP20
- _ Casing: plastic, white
- _ UV stabilized plastic
- _ DALI MSensor 5DPI 14 is powered via DALI circuit, basicDIM DGC Sensor 5DPI 14f powered via control unit
- _ Optional shutter to reduce the detection area, which makes it possible to reduce the detection area from 360° to 240° (for PIR sensors)
- _ Mounting kit with screws and decorative plugs
- _ 0.5 mm² wiring for the sensor
- _ Two 3 x 1.5 mm² clamps with cable management (2 entry points on opposite sides)
- _ Glow wire test with 750 °C according to EN 61347-1
- _ Sensor not included

Website

<http://www.tridonic.com/28001872>

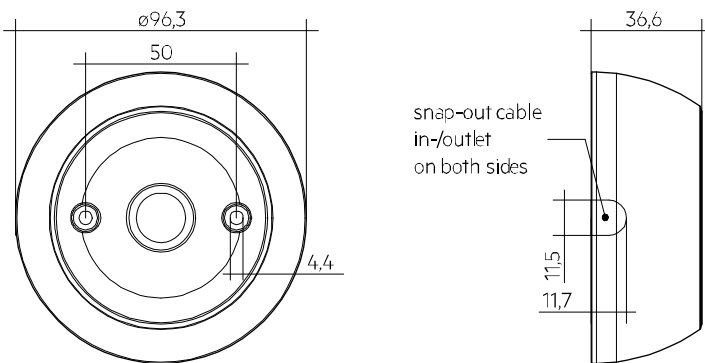

Ordering data

Type	Article number	Packaging, carton	Weight per pc.
ACU Sensor Housing 14rs IP20	28001872	81 pc(s).	0.054 kg

1. Standards

EN 61547
EN 61347-1
EN 61347-2-11
EN 55015
EN 62386-101/102

1.1 DALI standard

The DALI MSensor is designed to control control gear with DALI standard IEC 60929 (DALI V0) and IEC 62386 (DALI V1).

1.2 Glow wire test

according to EN 61347-1 passed.

2. Common

The DALI MSensor is the ideal addition to the comfortDIM series of products as it offers daylight-dependent lighting control, presence detection and remote control.

It has been designed for the following principal applications:

- Individual offices
- Open-plan offices
- Training / presentation rooms
- Corridors, passageways and garages

The DALI MSensor controls a DALI group and is designed that it can be used together with the comfortDIM components (e.g. DALI-XC). For this reason the DALI MSensor can be addressed and grouped like an ECG, making system configuration easier. The configuration of the sensors is done by the masterCONFIGURATOR software tool (since version V2.12). For further information please refer to the DALI MSensor manual on www.tridonic.com. As an option, the DALI MSensor O2 can be operated with a remote control. The remote control available with the system is the REMOTECONTROL IR6.

A maximum of 12 sensors can be operated on one DALI circuit. This restriction is due to the permitted data traffic on the DALI circuit.

To use the DALI MSensor in conjunction with an external system some modes are available. To ensure a proper function please take account of the advices in the DALI MSensor manual on www.tridonic.com.

3. Installation

- The DALI MSensor must not be connected to the mains. It is supplied directly via the DALI signal line.
- A maximum of 12 DALI MSensors must be operated in one DALI circuit.
- DALI is not SELV.
The installation instructions for mains voltage therefore apply.
- Please ensure that the detection range of the sensor lies in the lighting area of the controlled luminaires.
- Please ensure that the detection ranges of the sensors do not overlap.
This may have influence to the lighting control.
- When installed at a height other than the recommended installation height (2,5m), the presence sensor might show different characteristics. When mounted at a higher level, its sensitivity is reduced. If mounted at a lower level, its range is diminished.
- Heaters, fans, printers and copiers located in the detection zone may cause incorrect presence detection.
- Avoid direct illumination of the light source on the sensor including housing.

3.1 Wiring

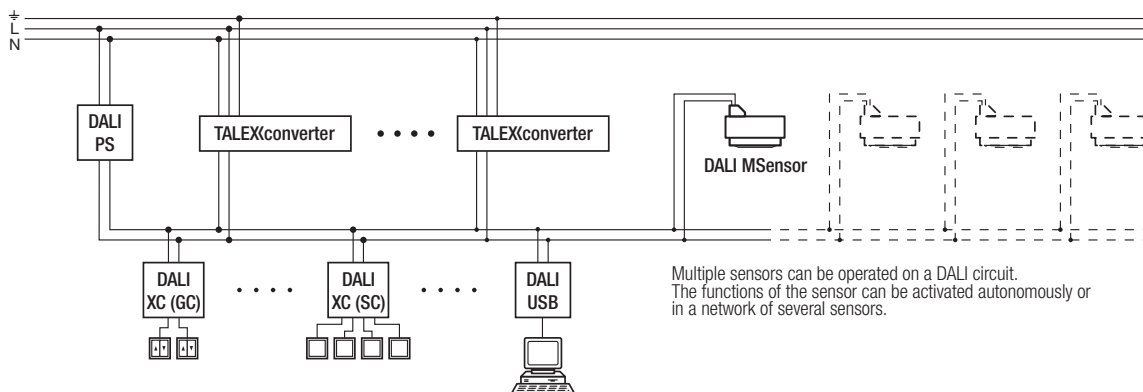

3.2 Wiring type and cross section for rc version

For wiring use stranded wire with ferrules or solid wire from 0.2 to 1.5 mm².

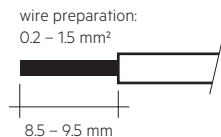

3.3 Wiring type and cross section for f version

For wiring use stranded wire with ferrules from 0.2 to 0.5 mm² or solid wire from 0.14 to 0.5 mm².

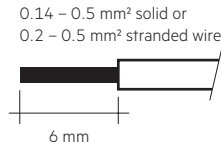

3.4 Mounting variants luminaire installation sensor:

Size of the sheet: 0.8 – 1.8 mm

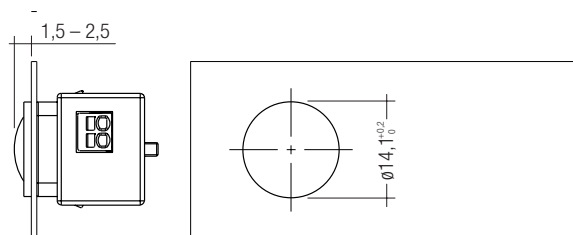

Size of the sheet: 0.6 – 0.8 mm

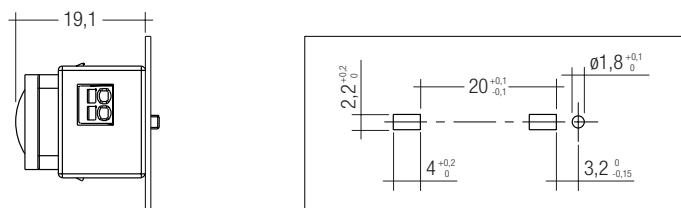

Size of the sheet: 0.8 – 3.0 mm

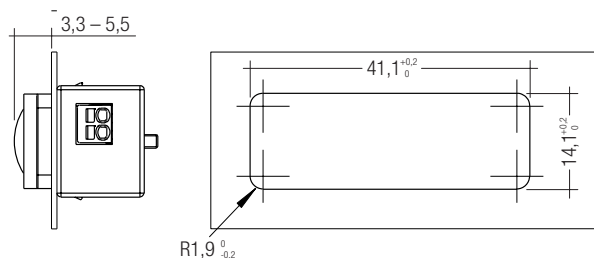

3.5 Mounting in luminaire housing with Mounting Kit:

Size of the sheet: 0.8 – 2.0 mm

Dimension drawing for needed mounting opening

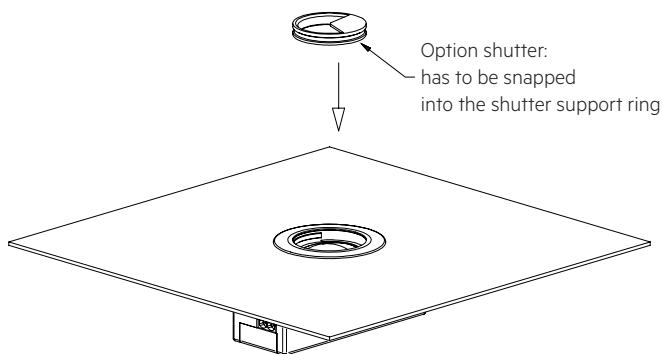
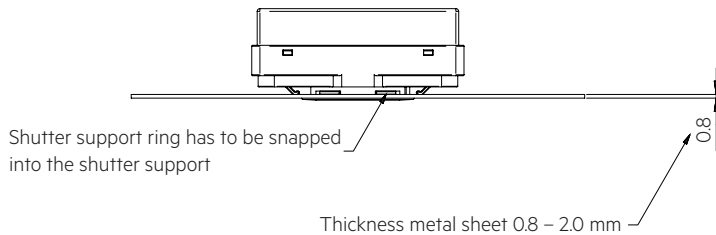
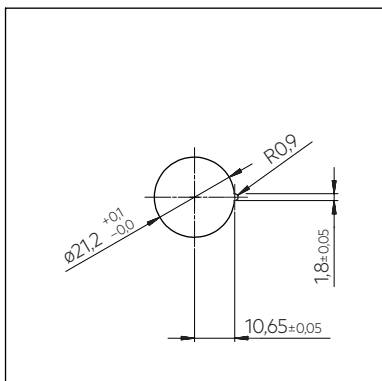

3.6 Mounting Kit mounting

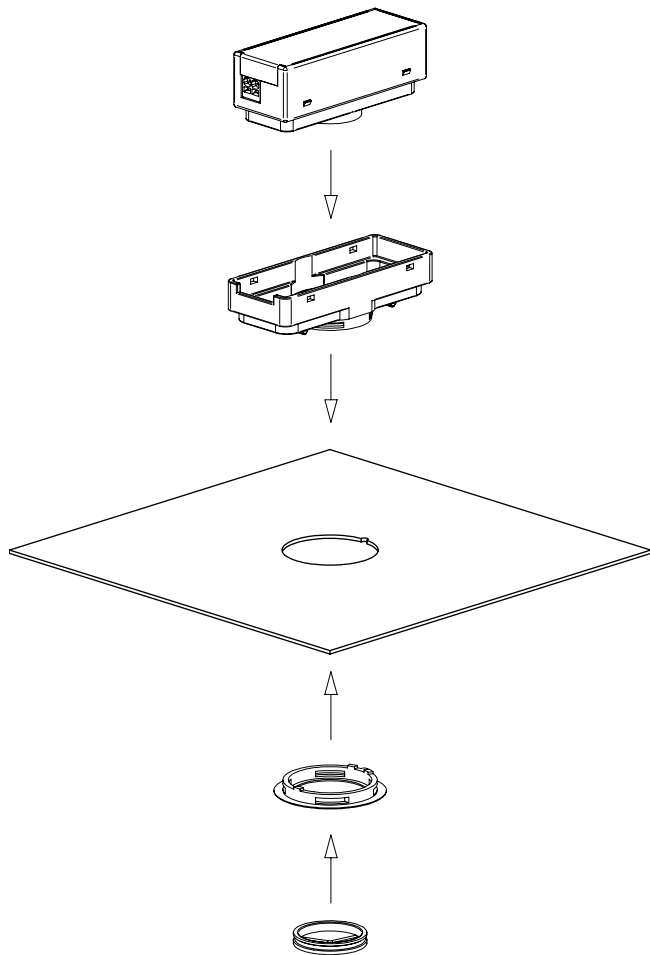

3.7 Mounting Kit Shutter

Area which is masked by the shutter.

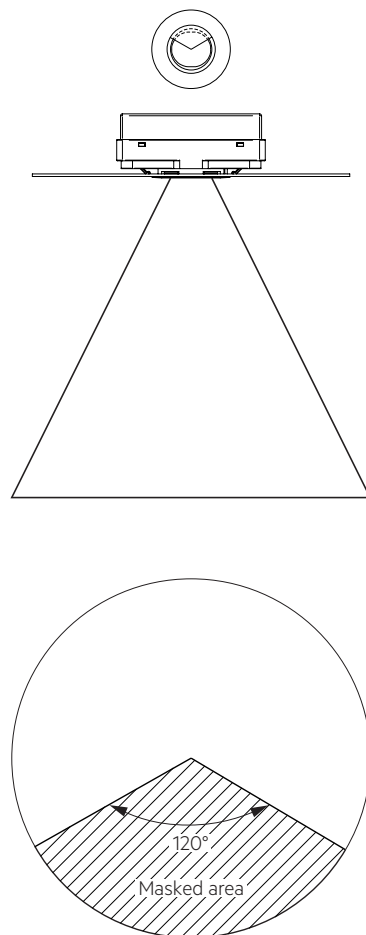

3.8 Wiring and mounting ACU Sensor Housing 14rs IP20

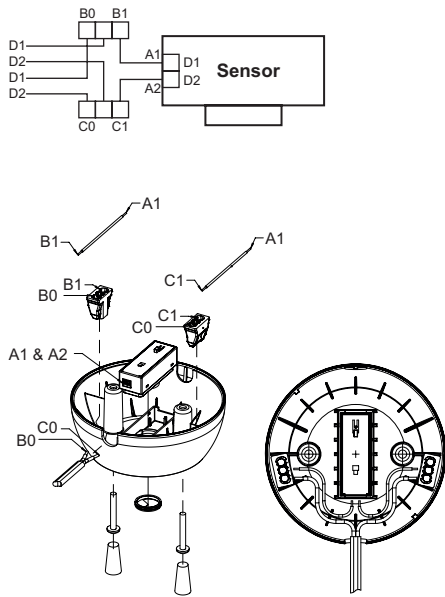

3.9 Mounting in class II luminaire

The Sensor provides basic insulation as required by IEC 62386-101 and defined in IEC 61347-1. If the sensor is built in to a class II luminaire which has to provide double or reinforced insulation it has to be considered that the Sensor is not a class II device. Still the Sensor can be used for such projects as the front of the sensor is tested to fulfill the class II requirements for double or reinforced insulation.

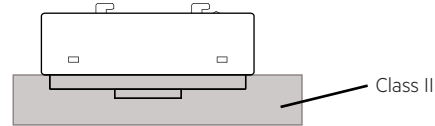

4. Light level recognition area

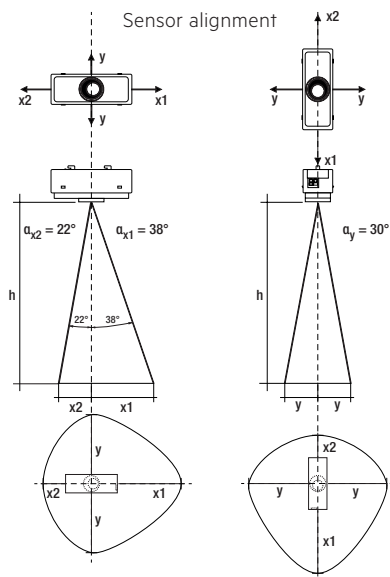

Example for light and motion detection area at height of 1.7 m:

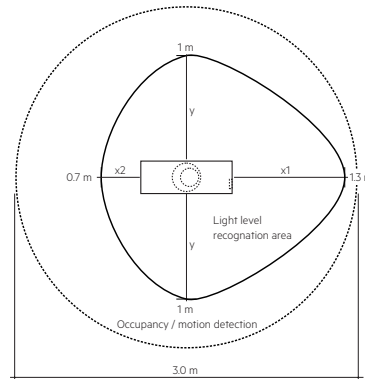

h *	x1	x2	y	d
1.7 m	1.3 m	0.7 m	1.0 m	3.0 m
2.0 m	1.6 m	0.8 m	1.2 m	3.6 m
2.3 m	1.8 m	0.9 m	1.3 m	4.1 m
2.5 m	2.0 m	1.0 m	1.4 m	4.5 m
2.7 m	2.1 m	1.1 m	1.6 m	4.9 m
3.0 m	2.3 m	1.2 m	1.7 m	5.4 m
3.5 m	2.7 m	1.4 m	2.0 m	6.3 m
4.0 m	3.1 m	1.6 m	2.3 m	7.2 m

* The recommended maximum room height for office applications is 3 m and for corridor applications for example 4 m. Up to 2 m mounting height presence is detected and over 2 m motion is detected.

Calculation of the diameter (light area):
 $x1 = \tan(\alpha_{x1}) \times h$
 $x2 = \tan(\alpha_{x2}) \times h$
 $y = \tan(\alpha_y) \times h$

Calculation of the diameter (motion area):
 $d = 2 \times \tan(0,5 \times \alpha) \times h$

The following operating modes can be set for lighting control via the masterCONFIGURATOR configuration software:

Active	Constant light control is active.
Inactive	Constant light control is deactivated. The lighting is switched on an adjustable light value.

4.1 Presence / motion detection

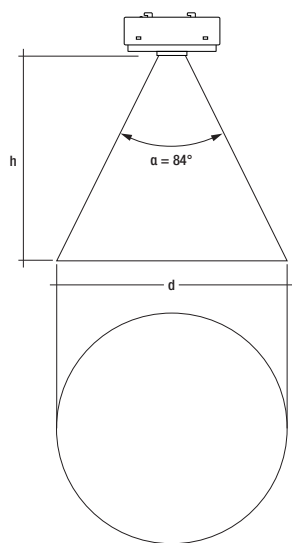

4.2 Motion detection

For motion detection PIR technology is used. PIR Lens is made to detect moving people in working areas such as warehouses, storage buildings and similar working areas with the following performance criteria:

- Ceiling height from up to 5 m
- Movement of human body, no slight motion (no sitting person)
- Movement ≥ 1.0 m/s for mounting heights up to 5 m

4.3 Setpoint adjustment

- REMOTECONTROL IR6: Pressing the Set button (> 3 s) stores the current light value as a new setpoint.
- masterCONFIGURATOR

4.4 Bright-out

If the nominal illuminance (e.g. 500 lux) is exceeded for 10 minutes by more than 150 % (e.g. 750 lux), the lighting is switched off even if motion is detected. The lighting is switched on again when the measured light value falls below the setpoint.

This function can be adjusted via the masterCONFIGURATOR.

4.5 Run-on time

This is the time after which the lighting is switched off if no movement is detected. It can be set via the "Run-on time" parameter.

The following operating modes can be set for the motion detector via the masterCONFIGURATOR configuration software:

Active	The light is switched on or off automatically depending on whether or not there is a person in the room.
Off Only	The motion detector only switches the connected lighting off. The luminaires are switched on manually via the connected external switch or infra-red control.
Never Off	If it has not detected any movement the sensor dims to the "Absence value" parameter and remains at this value
Inactive	The motion sensor is deactivated. The light must be switched on or off manually.

4.6 Absence value

On the DALI MSensor you can set whether the light is to be switched off after the switch-off delay or dimmed to the second light value. The light value and the dwell time (how long the value is held) can be set via the "Absence value" and "Switch-off delay" parameters.

4.7 Dead time "Manual-off"

If the system is switched off manually via the switch or remote control the motion sensor is deactivated. At the end of a delay time if motion has not been detected the motion sensor is activated again. If the sensor detects motion during the "Manual-off" delay, the time will be reset to the start.

4.8 General settings

Parameter	Default Values	Adjustable range
Motion Detector	enabled	enabled, enabled (only OFF), disabled
Light Regulation	enabled	enabled, disabled
Setpoint Light Regulation	150 lx	10 – 650 lx
Power On Setting	no action	no action, last state, maximum level, off, presence value
Bright-out timeout	10 min	1 – 120 min
Bright-out threshold	150 %	100 – 300 %
Control Speed	4	0 – 7, 0 = slow, 7 = fast
Switch On Value	auto (calculated)	minimum level, maximum level, calculated
Controlled group	Broadcast	Broadcast or group 0 – 15

4.9 Default Parameter Motion Detector

Parameter	Default Values	Adjustable range
1 Fade-in time	fast	fast, 0.7 – 90.5 s
A Presence value	ambient light-controlled	ambient light-controlled, fixed
2 Run-on time	20 min	30 s – 60 min, infinite
3 Fade time	5.6 s	fast, 0.7 – 90.5 s
B Absence value	3 %	1 – 100 %
4 Switch-off delay	10 min	0.7 s – 60 min, never OFF
5 Fade-off time	5.6 s	fast, 0.7 – 90.5 s
Manual-off	10 min	fast, 0 s – 20 min

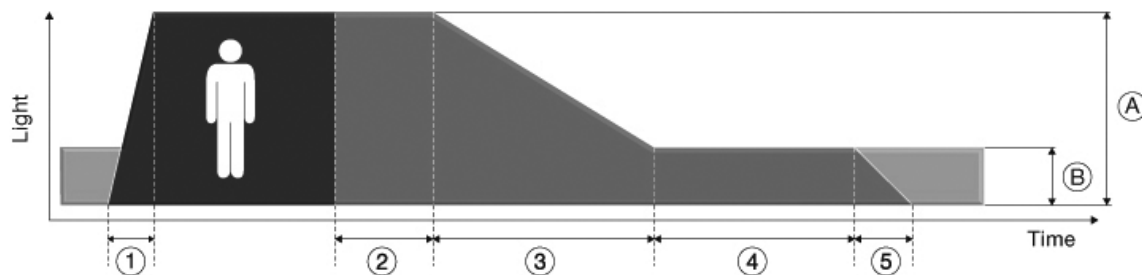

5. Remote control

The DALI MSensor O2 can be controlled with a remote control:

- REMOTECONTROL IR6

5.1 REMOTECONTROL IR6

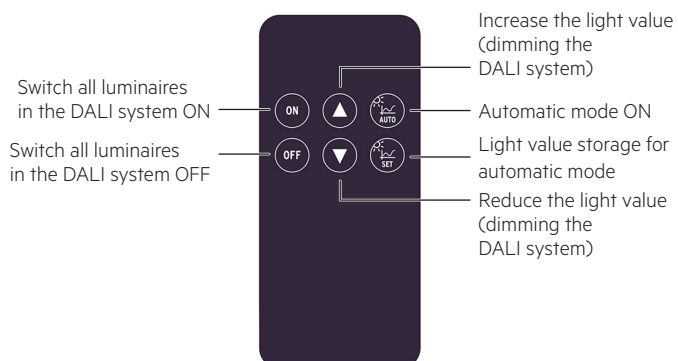

6. Miscellaneous

6.1 Disposal



According to the WEEE directive return old equipment at appropriate collection facilities.

6.2 Additional information

Additional technical information at www.tridonic.com → Technical Data

Guarantee conditions at www.tridonic.com → Services

Lifetime declarations are informative and represent no warranty claim. No warranty if device was opened.