

Constant current linear dimmable driver
BHL Series suffix M(1-10V/10V PWM)



Features

- 1-10V/10V PWM dimming interface
- 10-level current output can be realized by DIP-switch
- Soft dimming and flicker-free at any brightness, meets the new requirements of ErP certification
- Using HPC patented technology at any dimming level, the brightness of the lamps is the same
- Standby power input < 0.5W, meets the requirements of ErP certification
- High PF, high efficiency, low THD
- SELV and Class I design, suitable for use inside of the light
- Compliance with CE, ENEC, UKCA, RCM, CCC, DALI-2, EL and other certifications
- IP20 protection grade, indoor use
- Nominal life-time up to 100,000 h
- 5-year guarantee

Interfaces

- DIM(1-10V / 10V PWM)

Functions

- Support central emergency application (dimming normal in DC input)
- Support self-contained emergency application
- Protective features (short-circuit, overload, no-load protection)

Suitable for lights

- Suitable for linear lights, tri-proof lights, working lights and other linear or ultra-thin lights etc.

Typical applications

- LED indoor lighting
- LED office lighting
- LED commercial lighting

Model coding rules of BHL series

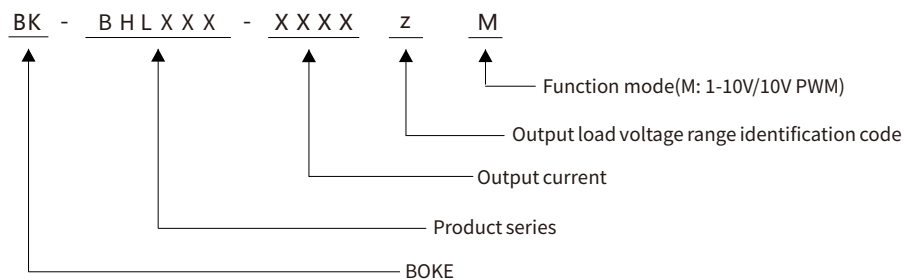

Function list

Model	Suffix	Wired dimming	
		DALI-2	1-10V 3in1
BK-BHL030 BK-BHL040 BK-BHL050	M		√
BK-BHL060 BK-BHL070	D	√	

* The description in this specification is only applicable to the products with the suffix M and the model are BHL030,BHL040,BHL050,BHL060 and BHL070 .

Model list

Model	Input voltage	Output power	Output voltage	Output current	Dimension	Certifications
BK-BHL030-0750AM	200-240VAC/DC	30W MAX.	3-40/42VDC	0.3-0.75A	L245*W30*H21mm	CE, ENEC, UKCA, RCM, CCC, EL
BK-BHL030-0750AD	200-240VAC/DC	30W MAX.	3-40/42VDC	0.3-0.75A	L245*W30*H21mm	CE, ENEC, UKCA, RCM, CCC, DALI-2, EL
BK-BHL040-1000AM	200-240VAC/DC	40W MAX.	3-40/42VDC	0.55-1A	L285*W30*H21mm	CE, ENEC, UKCA, RCM, CCC, EL
BK-BHL040-1000AD	200-240VAC/DC	40W MAX.	3-40/42VDC	0.55-1A	L285*W30*H21mm	CE, ENEC, UKCA, RCM, CCC, DALI-2, EL
BK-BHL050-1250AM	200-240VAC/DC	50W MAX.	3-40/41.5/42VDC	0.8-1.25A	L285*W30*H21mm	CE, ENEC, UKCA, RCM, CCC, EL
BK-BHL050-1250AD	200-240VAC/DC	50W MAX.	3-40/41.5/42VDC	0.8-1.25A	L285*W30*H21mm	CE, ENEC, UKCA, RCM, CCC, DALI-2, EL
BK-BHL060-1650AM	200-240VAC/DC	60W MAX.	3-36/37.5/38.5/40/41/42VDC	1.2-1.65A	L355*W30*H21mm	CE, ENEC, UKCA, RCM, CCC, EL
BK-BHL060-1650AD	200-240VAC/DC	60W MAX.	3-36/37.5/38.5/40/41/42VDC	1.2-1.65A	L355*W30*H21mm	CE, ENEC, UKCA, RCM, CCC, DALI-2, EL
BK-BHL070-2000AM	200-240VAC/DC	70.3W MAX.	3-35/37/39/41/42VDC	1.3-2A	L355*W36*H23mm	CE, ENEC, UKCA, RCM, CCC, EL
BK-BHL070-2000AD	200-240VAC/DC	70.3W MAX.	3-35/37/39/41/42VDC	1.3-2A	L355*W36*H23mm	CE, ENEC, UKCA, RCM, CCC, DALI-2, EL

* The description in this specification is only applicable to the products with the suffix M and the model are BHL030,BHL040,BHL050,BHL060 and BHL070 .

Technical data

Product model	BK-BHL030-0750AM
Output parameters	
Regulation method	Constant Current
Rated output current range	0.3-0.75A
Rated output voltage range	3-40/42VDC
Rated output power	30W Max
Output current adjustment	DIP S.W(10 levels)
Output current ripple LF	±2%
Output current accuracy	±2%
Linear regulation	±1%
Load regulation	±1%
No load output voltage	50VDC
Flicker-free(typical)	Flickering percent(IEEE 1789)=0.126%, Flicker index(IEEE 1789)=0.001, Pst LM = 0.000, SVM = 0.003, (The above parameters are obtained from testing the panel lights)
Input parameters	
Rated input voltage range	200-240VAC 200-240VDC
Input voltage range	180-264VAC 200-264VDC
Input voltage shock	<380 VAC
Input current	<0.25A (Rated input voltage)
Input frequency	0/50/60Hz
Input PF/Input DF	PF: 0.98,DF: 0.98,see the electrical values below for details
Input THD	5%,see the electrical values below for details
Efficiency(Max)	87.5% ,see the electrical values below for details
In-rush current	7.48A peak ,194us duration(50 % Ipeak), see the description below for details
Start/Switchover/Turn off	<0.5s(AC start),<0.5s(DC start),<0.3s(AC/DC switchover),<0.5s(Turn off)
Switching cycles	> 50,000 switching cycles
Power consumption	Full load(Pin):34.3W, No load(Pno): N/A, On stand-by(Psb) : <0.5W, Network stand-by(Pnet) : N/A
Safety	
Withstand voltage	I/P-O/P:3750VAC,I/P-FG:1750VAC,O/P-FG:500VAC , I/P-DIM: 1500V AC , O/P-DIM: 1500V AC.
Mains surge capability	L-N:2KV,L-FG/N-FG:2KV
Leakage current	<0.7mA (230V AC & Full load)
Isolation resistance	I/P-O/P:100MΩ/500Vdc/25°C/70% RH
Control interface	
DALI dimming port	N/A
pushDIM dimming port	N/A
1-10V 3in1 dimming port	Dimming range: 0-10V, interface current consumption: 0.3mA
Auxiliary power supply	N/A
Dimming range	1%-100%
Dimming drive mode	AM(amplitude modulation)
Emergency support	
Central emergency system	Supported (dimming normal in DC input)
Self-contained emergency	Supported
Environment & Life time	
Operating temperature	Ta=-20-60°C
Case temperature	Tc=90°C
Operating humidity	5-85% RH, not condensed
Storage temp./humidity	-40-80°C, 5-85% RH, not condensed
IP grade	IP20
MTBF	500,000H,MIL-HDBK-217F(25°C)
Life-time	Nominal life-time up to 100,000 h, see the description below for details
Vibration resistant	10~500Hz,5G 12min./1cycle,period for 72min. each along X,Y,Z axes
Acoustic Noise	<25dB(30cm, Normal operation)
Environmental protection	RoHS
Certifications and standards	
Certification	CE, ENEC, UKCA, RCM, CCC, EL
Safety	EN61347-1, EN61347-2-13, EN62384
EMC	EN55015, EN61000-3-2 , EN61000-3-3, EN61000-4-2,3,4,5,6,8,11, EN61547
DALI-2	N/A
EL	Compatible IEC 61347-2- 13 Annex J , compatible with EN 60598-2-22 and EN 50172
RF	N/A

Remarks

1.By default, all parameter are measured at 230VAC input, full load and 25°C of ambient temperature.

Technical data

Product model	BK-BHL040-1000AM
Output parameters	
Regulation method	Constant Current
Rated output current range	0.55-1A
Rated output voltage range	3-40/42VDC
Rated output power	40W Max
Output current adjustment	DIP S.W(10 levels)
Output current ripple LF	±2%
Output current accuracy	±2%
Linear regulation	±1%
Load regulation	±1%
No load output voltage	50VDC
Flicker-free(typical)	Flickering percent(IEEE 1789)=0.328%, Flicker index(IEEE 1789)=0.001, Pst LM = 0.003, SVM = 0.005, (The above parameters are obtained from testing the panel lights)
Input parameters	
Rated input voltage range	200-240VAC 200-240VDC
Input voltage range	180-264VAC 200-264VDC
Input voltage shock	<380 V AC
Input current	<0.3A (Rated input voltage)
Input frequency	0/50/60Hz
Input PF/Input DF	PF: 0.98,DF: 0.98,see the electrical values below for details
Input THD	5%,see the electrical values below for details
Efficiency(Max)	89.5% ,see the electrical values below for details
In-rush current	8.65A peak ,186us duration(50 % Ipeak), see the description below for details
Start/Switchover/Turn off	<0.5s(AC start),<0.5s(DC start),<0.3s(AC/DC switchover),<0.5s(Turn off)
Switching cycles	> 50,000 switching cycles
Power consumption	Full load(Pin):44.7W, No load(Pno): N/A, On stand-by(Psb) : <0.5W, Network stand-by(Pnet) : N/A
Safety	
Withstand voltage	I/P-O/P:3750VAC,I/P-FG:1750VAC,O/P-FG:500VAC , I/P-DIM: 1500V AC , O/P-DIM: 1500V AC.
Mains surge capability	L-N:2KV,L-FG/N-FG:2KV
Leakage current	<0.7mA (230V AC & Full load)
Isolation resistance	I/P-O/P:100MΩ/500Vdc/25°C/70% RH
Control interface	
DALI dimming port	N/A
pushDIM dimming port	N/A
1-10V 3in1 dimming port	Dimming range: 0-10V, interface current consumption: 0.3mA
Auxiliary power supply	N/A
Dimming range	1%-100%
Dimming drive mode	AM(amplitude modulation)
Emergency support	
Central emergency system	Supported (dimming normal in DC input)
Self-contained emergency	Supported
Environment & Life time	
Operating temperature	Ta=-20-60°C
Case temperature	Tc=90°C
Operating humidity	5-85% RH, not condensed
Storage temp./humidity	-40-80°C, 5-85% RH, not condensed
IP grade	IP20
MTBF	500,000H,MIL-HDBK-217F(25°C)
Life-time	Nominal life-time up to 100,000 h, see the description below for details
Vibration resistant	10~500Hz,5G 12min./1cycle,period for 72min. each along X,Y,Z axes
Acoustic Noise	<25dB(30cm, Normal operation)
Environmental protection	RoHS
Certifications and standards	
Certification	CE, ENEC, UKCA, RCM, CCC, EL
Safety	EN61347-1, EN61347-2-13, EN62384
EMC	EN55015, EN61000-3-2 , EN61000-3-3, EN61000-4-2,3,4,5,6,8,11, EN61547
DALI-2	N/A
EL	Compatible IEC 61347-2- 13 Annex J , compatible with EN 60598-2-22 and EN 50172
RF	N/A

Remarks

1.By default, all parameter are measured at 230VAC input, full load and 25°C of ambient temperature.

Technical data

Product model	BK-BHL050-1250AM
Output parameters	
Regulation method	Constant Current
Rated output current range	0.8-1.25A
Rated output voltage range	3-40/41.5/42VDC
Rated output power	50W Max
Output current adjustment	DIP S.W(10 levels)
Output current ripple LF	±2%
Output current accuracy	±2%
Linear regulation	±1%
Load regulation	±1%
No load output voltage	50VDC
Flicker-free(typical)	Flickering percent(IEEE 1789)=0.430%, Flicker index(IEEE 1789)=0.001, Pst LM = 0.003, SVM = 0.007, (The above parameters are obtained from testing the panel lights)
Input parameters	
Rated input voltage range	200-240VAC 200-240VDC
Input voltage range	180-264VAC 200-264VDC
Input voltage shock	<380 VAC
Input current	<0.35A (Rated input voltage)
Input frequency	0/50/60Hz
Input PF/Input DF	PF: 0.98,DF: 0.98,see the electrical values below for details
Input THD	6%,see the electrical values below for details
Efficiency(Max)	91% ,see the electrical values below for details
In-rush current	8.31A peak ,201us duration(50 % Ipeak), see the description below for details
Start/Switchover/Turn off	<0.5s(AC start),<0.5s(DC start),<0.3s(AC/DC switchover),<0.5s(Turn off)
Switching cycles	> 50,000 switching cycles
Power consumption	Full load(Pin):54.9W, No load(Pno): N/A, On stand-by(Psb) : <0.5W, Network stand-by(Pnet) : N/A
Safety	
Withstand voltage	I/P-O/P:3750VAC,I/P-FG:1750VAC,O/P-FG:500VAC , I/P-DIM: 1500V AC , O/P-DIM: 1500V AC.
Mains surge capability	L-N:2KV,L-FG/N-FG:2KV
Leakage current	<0.7mA (230V AC & Full load)
Isolation resistance	I/P-O/P:100MΩ/500Vdc/25°C/70% RH
Control interface	
DALI dimming port	N/A
pushDIM dimming port	N/A
1-10V 3in1 dimming port	Dimming range: 0-10V, interface current consumption: 0.3mA
Auxiliary power supply	N/A
Dimming range	1%-100%
Dimming drive mode	AM(amplitude modulation)
Emergency support	
Central emergency system	Supported (dimming normal in DC input)
Self-contained emergency	Supported
Environment & Life time	
Operating temperature	Ta=-20-60°C
Case temperature	Tc=90°C
Operating humidity	5-85% RH, not condensed
Storage temp./humidity	-40-80°C, 5-85% RH, not condensed
IP grade	IP20
MTBF	500,000H,MIL-HDBK-217F(25°C)
Life-time	Nominal life-time up to 100,000 h, see the description below for details
Vibration resistant	10~500Hz,5G 12min./1cycle,period for 72min. each along X,Y,Z axes
Acoustic Noise	<25dB(30cm, Normal operation)
Environmental protection	RoHS
Certifications and standards	
Certification	CE, ENEC, UKCA, RCM, CCC, EL
Safety	EN61347-1, EN61347-2-13, EN62384
EMC	EN55015, EN61000-3-2 , EN61000-3-3, EN61000-4-2,3,4,5,6,8,11, EN61547
DALI-2	N/A
EL	Compatible IEC 61347-2- 13 Annex J , compatible with EN 60598-2-22 and EN 50172
RF	N/A

Remarks

1.By default, all parameter are measured at 230VAC input, full load and 25°C of ambient temperature.

Technical data

Product model	BK-BHL060-1650AM
Output parameters	
Regulation method	Constant Current
Rated output current range	1.2-1.65A
Rated output voltage range	3-36/37.5/38.5/40/41/42VDC
Rated output power	60W Max
Output current adjustment	DIP S.W(10 levels)
Output current ripple LF	±2%
Output current accuracy	±2%
Linear regulation	±1%
Load regulation	±1%
No load output voltage	50VDC
Flicker-free(typical)	Flickering percent(IEEE 1789)=0.134%, Flicker index(IEEE 1789)=0.001, Pst LM = 0.013, SVM = 0.002, (The above parameters are obtained from testing the panel lights)
Input parameters	
Rated input voltage range	200-240VAC 200-240VDC
Input voltage range	180-264VAC 200-264VDC
Input voltage shock	<380 VAC
Input current	<0.45A (Rated input voltage)
Input frequency	0/50/60Hz
Input PF/Input DF	PF: 0.98,DF: 0.98,see the electrical values below for details
Input THD	5%,see the electrical values below for details
Efficiency(Max)	91.5% ,see the electrical values below for details
In-rush current	8.23A peak ,196us duration(50 % Ipeak), see the description below for details
Start/Switchover/Turn off	<0.5s(AC start),<0.5s(DC start),<0.3s(AC/DC switchover),<0.5s(Turn off)
Switching cycles	> 50,000 switching cycles
Power consumption	Full load(Pin):65.6W, No load(Pno): N/A, On stand-by(Psb) : <0.5W, Network stand-by(Pnet) : N/A
Safety	
Withstand voltage	I/P-O/P:3750VAC,I/P-FG:1750VAC,O/P-FG:500VAC , I/P-DIM: 1500V AC , O/P-DIM: 1500V AC.
Mains surge capability	L-N:2KV,L-FG/N-FG:2KV
Leakage current	<0.7mA (230V AC & Full load)
Isolation resistance	I/P-O/P:100MΩ/500Vdc/25°C/70% RH
Control interface	
DALI dimming port	N/A
pushDIM dimming port	N/A
1-10V 3in1 dimming port	Dimming range: 0-10V, interface current consumption: 0.3mA
Auxiliary power supply	N/A
Dimming range	1%-100%
Dimming drive mode	AM(amplitude modulation)
Emergency support	
Central emergency system	Supported (dimming normal in DC input)
Self-contained emergency	Supported
Environment & Life time	
Operating temperature	Ta=-20-60°C
Case temperature	Tc=90°C
Operating humidity	5-85% RH, not condensed
Storage temp./humidity	-40-80°C, 5-85% RH, not condensed
IP grade	IP20
MTBF	500,000H,MIL-HDBK-217F(25°C)
Life-time	Nominal life-time up to 100,000 h, see the description below for details
Vibration resistant	10~500Hz,5G 12min./1cycle,period for 72min. each along X,Y,Z axes
Acoustic Noise	<25dB(30cm, Normal operation)
Environmental protection	RoHS
Certifications and standards	
Certification	CE, ENEC, UKCA, RCM, CCC, EL
Safety	EN61347-1, EN61347-2-13, EN62384
EMC	EN55015, EN61000-3-2 , EN61000-3-3, EN61000-4-2,3,4,5,6,8,11, EN61547
DALI-2	N/A
EL	Compatible IEC 61347-2- 13 Annex J , compatible with EN 60598-2-22 and EN 50172
RF	N/A

Remarks

1.By default, all parameter are measured at 230VAC input, full load and 25°C of ambient temperature.

Technical data

Product model	BK-BHL070-2000AM
Output parameters	
Regulation method	Constant Current
Rated output current range	1.3-2A
Rated output voltage range	3-35/37/39/41/42VDC
Rated output power	70.3W Max
Output current adjustment	DIP S.W(10 levels)
Output current ripple LF	±2%
Output current accuracy	±2%
Linear regulation	±1%
Load regulation	±1%
No load output voltage	50VDC
Flicker-free(typical)	Flickering percent(IEEE 1789)=0.155%, Flicker index(IEEE 1789)=0.001, Pst LM = 0.002, SVM = 0.005, (The above parameters are obtained from testing the panel lights)
Input parameters	
Rated input voltage range	200-240VAC 200-240VDC
Input voltage range	180-264VAC 200-264VDC
Input voltage shock	<380 V AC
Input current	<0.5A (Rated input voltage)
Input frequency	0/50/60Hz
Input PF/Input DF	PF: 0.98,DF: 0.98,see the electrical values below for details
Input THD	6%,see the electrical values below for details
Efficiency(Max)	90% ,see the electrical values below for details
In-rush current	8.54A peak ,214us duration(50 % Ipeak), see the description below for details
Start/Switchover/Turn off	<0.5s(AC start),<0.5s(DC start),<0.3s(AC/DC switchover),<0.5s(Turn off)
Switching cycles	> 50,000 switching cycles
Power consumption	Full load(Pin):77.8W, No load(Pno): N/A, On stand-by(Psb) : <0.5W, Network stand-by(Pnet) : N/A
Safety	
Withstand voltage	I/P-O/P:3750VAC,I/P-FG:1750VAC,O/P-FG:500VAC , I/P-DIM: 1500V AC , O/P-DIM: 1500V AC.
Mains surge capability	L-N:2KV,L-FG/N-FG:2KV
Leakage current	<0.7mA (230V AC & Full load)
Isolation resistance	I/P-O/P:100MΩ/500Vdc/25°C/70% RH
Control interface	
DALI dimming port	N/A
pushDIM dimming port	N/A
1-10V 3in1 dimming port	Dimming range: 0-10V, interface current consumption: 0.3mA
Auxiliary power supply	N/A
Dimming range	1%-100%
Dimming drive mode	AM(amplitude modulation)
Emergency support	
Central emergency system	Supported (dimming normal in DC input)
Self-contained emergency	Supported
Environment & Life time	
Operating temperature	Ta=-20-60°C
Case temperature	Tc=90°C
Operating humidity	5-85% RH, not condensed
Storage temp./humidity	-40-80°C, 5-85% RH, not condensed
IP grade	IP20
MTBF	500,000H,MIL-HDBK-217F(25°C)
Life-time	Nominal life-time up to 100,000 h, see the description below for details
Vibration resistant	10~500Hz,5G 12min./1cycle,period for 72min. each along X,Y,Z axes
Acoustic Noise	<25dB(30cm, Normal operation)
Environmental protection	RoHS
Certifications and standards	
Certification	CE, ENEC, UKCA, RCM, CCC, EL
Safety	EN61347-1, EN61347-2-13, EN62384
EMC	EN55015, EN61000-3-2 , EN61000-3-3, EN61000-4-2,3,4,5,6,8,11, EN61547
DALI-2	N/A
EL	Compatible IEC 61347-2- 13 Annex J , compatible with EN 60598-2-22 and EN 50172
RF	N/A

Remarks

1.By default, all parameter are measured at 230VAC input, full load and 25°C of ambient temperature.

Electrical values

BK-BHL030-0750AM

Efficiency vs voltage

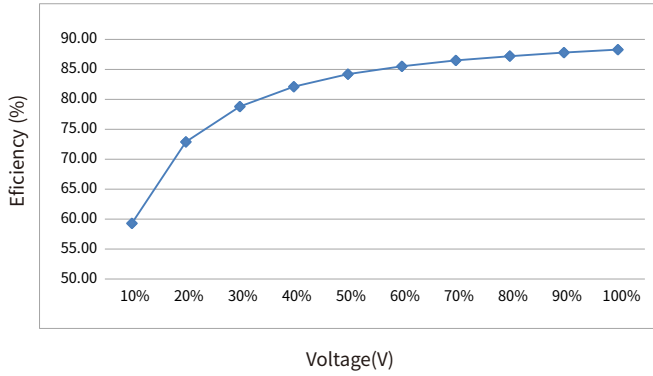

THD vs. voltage

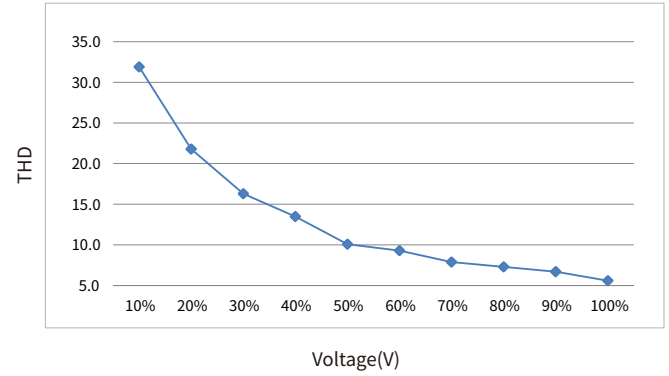

Power factor vs. voltage

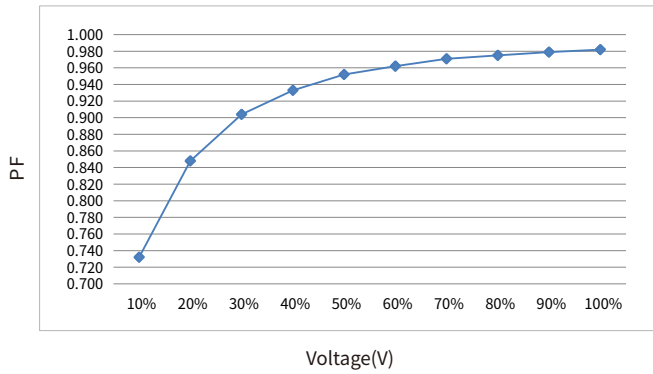

Displacement factor vs. voltage

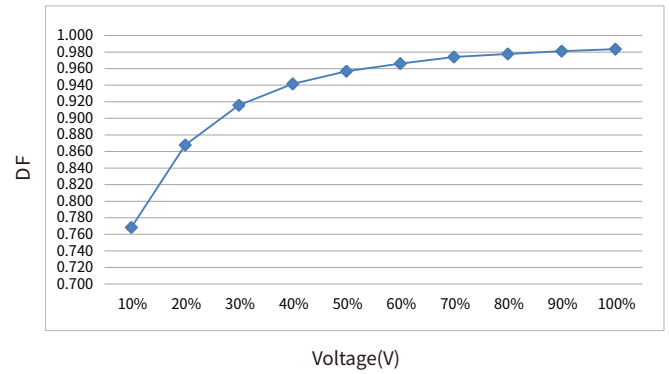

BK-BHL040-1000AM

Efficiency vs voltage

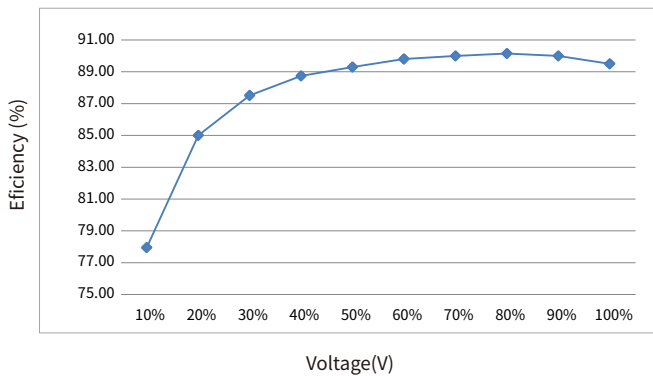

THD vs. voltage

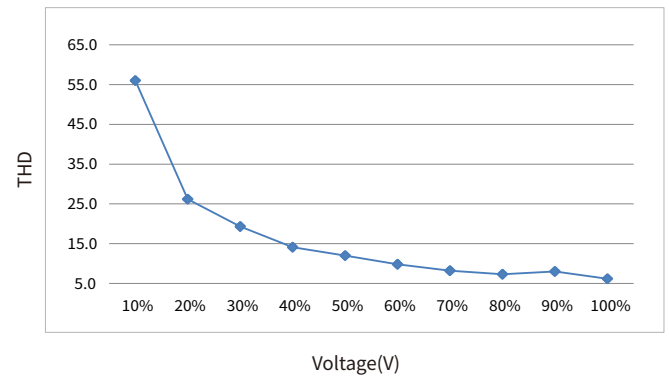

Power factor vs. voltage

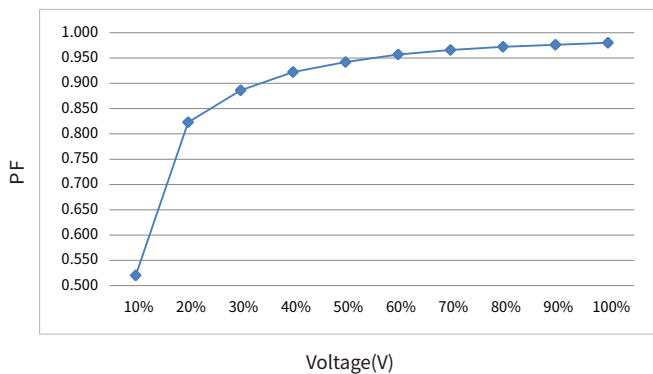

Displacement factor vs. voltage

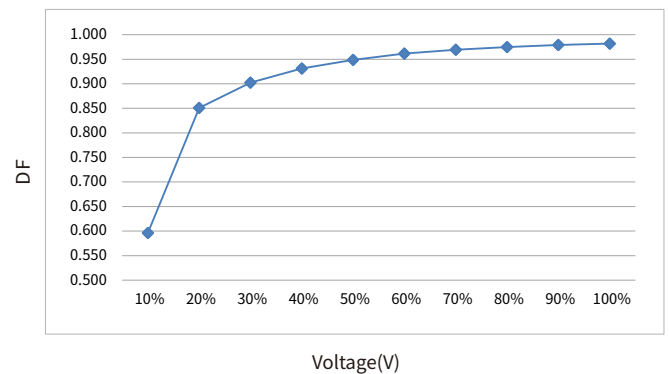

Electrical values

BK-BHL050-1250AM

Efficiency vs voltage

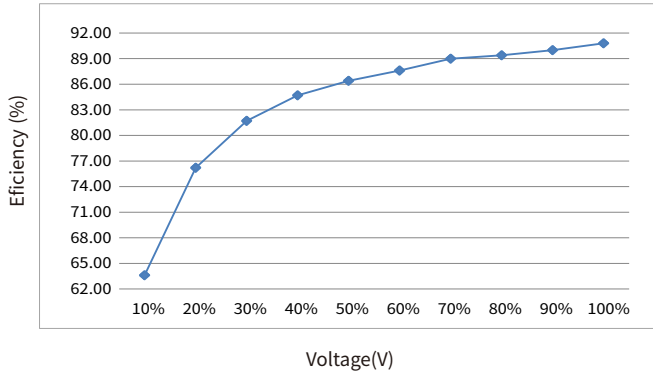

THD vs. voltage

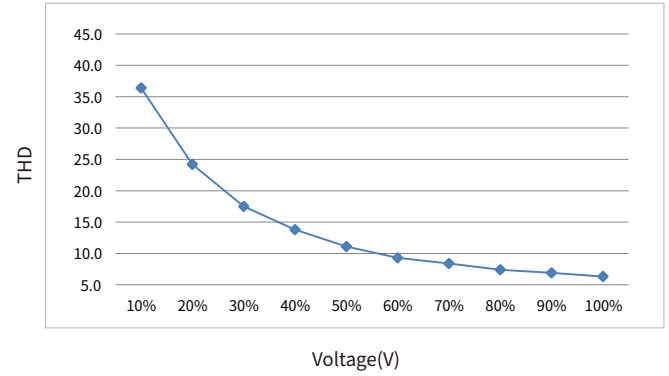

Power factor vs. voltage

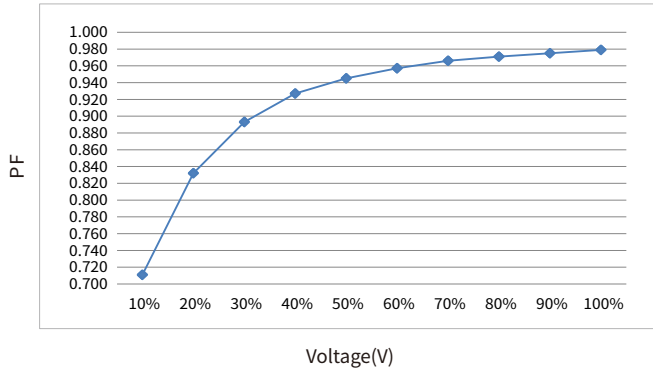

Displacement factor vs. voltage

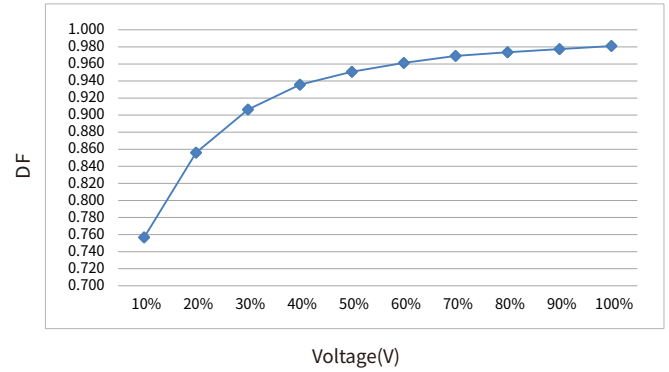

BK-BHL060-1650AM

Efficiency vs voltage

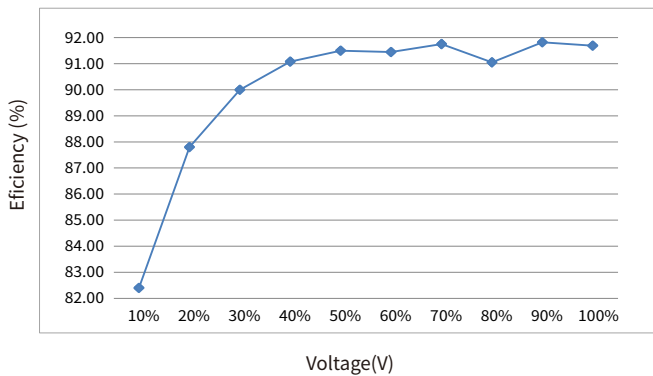

THD vs. voltage

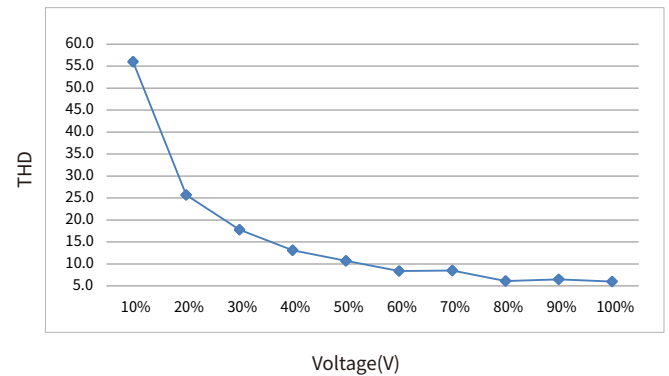

Power factor vs. voltage

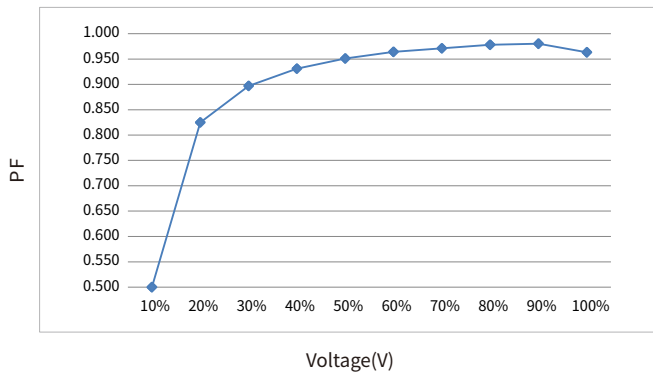

Displacement factor vs. voltage

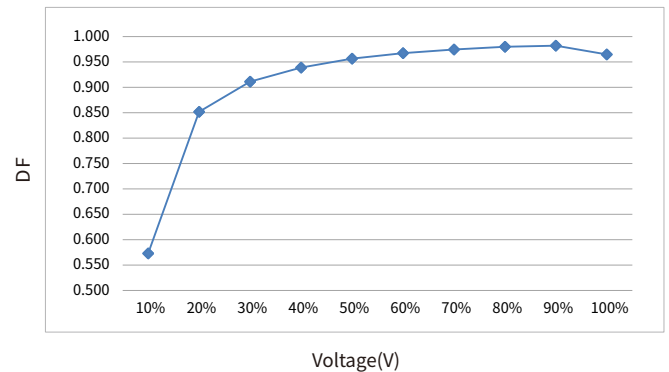

Electrical values

BK-BHL070-2000AM

Efficiency vs voltage

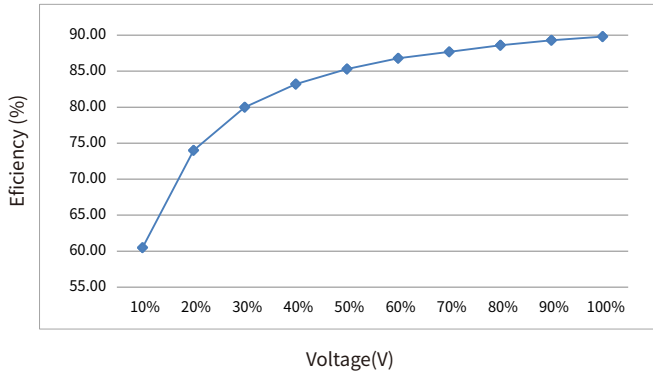

THD vs. voltage

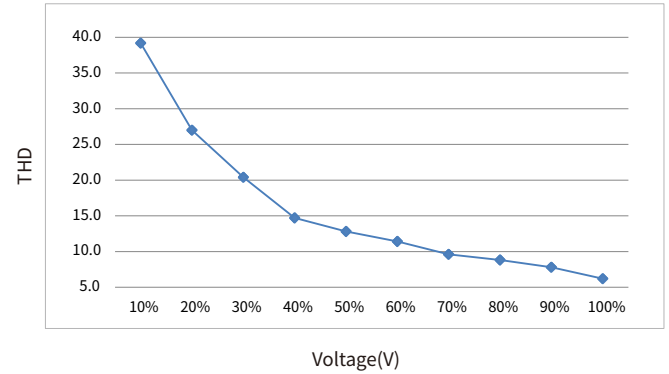

Power factor vs. voltage

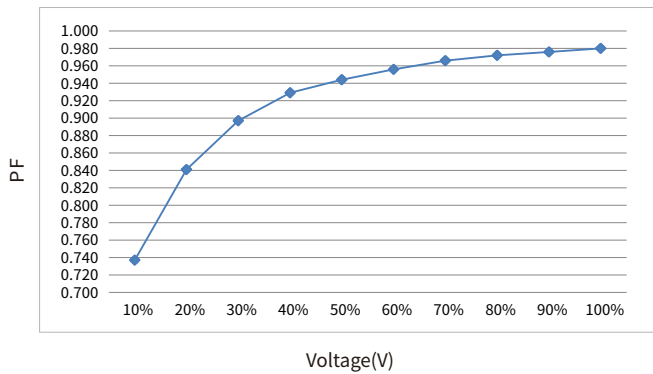

Displacement factor vs. voltage

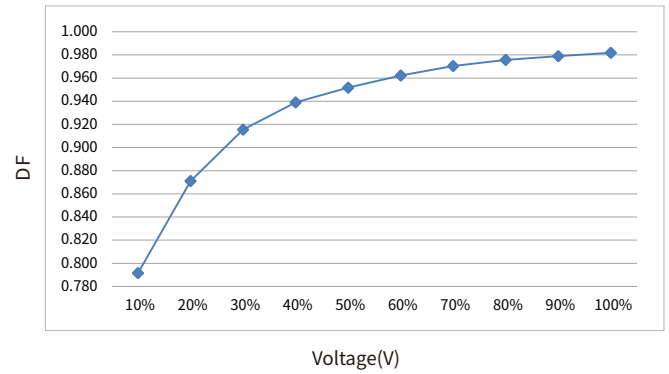

Expected life-time

BK-BHL030-0750AM

Life-time vs. case temperature

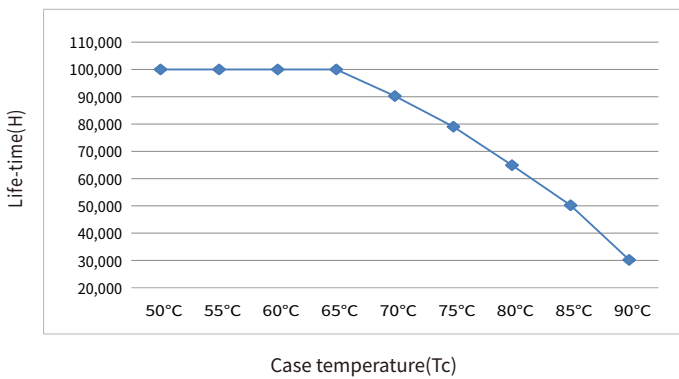

BK-BHL040-1000AM

Life-time vs. case temperature

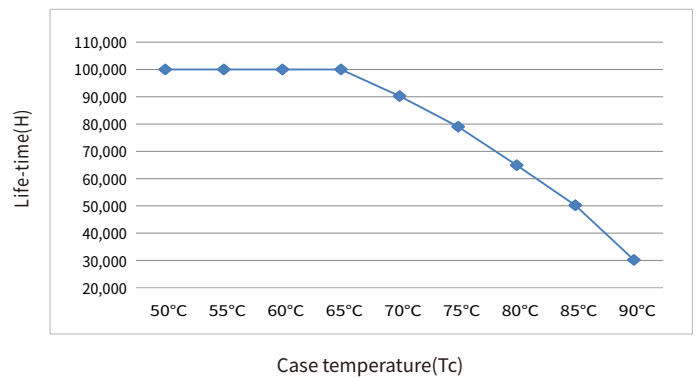

BK-BHL050-1250AM

Life-time vs. case temperature

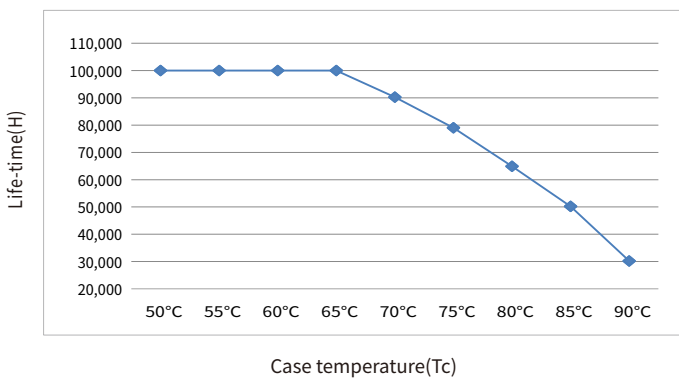

BK-BHL060-1650AM

Life-time vs. case temperature

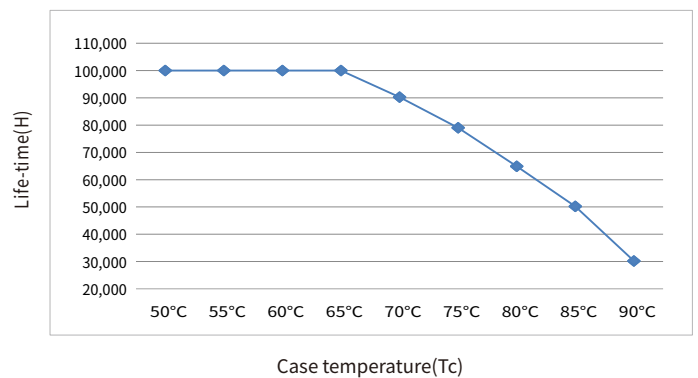

Expected life-time

BK-BHL070-2000AM

Life-time vs. case temperature

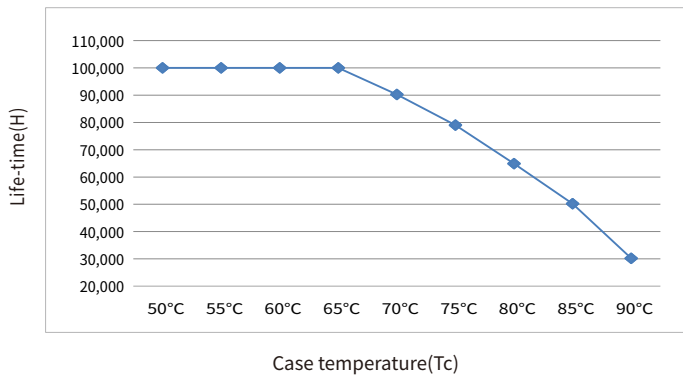

- The life-time of the LED driver is shown in the figure above (calculated based on the 90% survival rate).
- The relation of tc to ta temperature depends also on the luminaire design.

Surge

Model	Ipeak	Twidth	Condition	Relative number of MCB														
				B10	B13	B16	B20	B25	C10	C13	C16	C20	C25	D10	D13	D16	D20	D25
BK-BHL030-0750AM	7.48A	194us	AC 230V, Full load, Cold start, Ta ≤ 30°C, MCB is not installed side by side	43	55	68	85	107	45	59	73	91	113	45	59	73	91	113
BK-BHL040-1000AM	7.65A	186us		35	45	56	70	87	35	45	56	70	87	35	45	56	70	87
BK-BHL050-1250AM	8.31A	201us		28	36	45	56	70	28	36	45	56	70	28	36	45	56	70
BK-BHL060-1650AM	7.23A	196us		23	30	38	47	59	23	30	38	47	59	23	30	38	47	59
BK-BHL070-2000AM	8.54A	214us		20	26	32	40	50	20	26	32	40	50	20	26	32	40	50

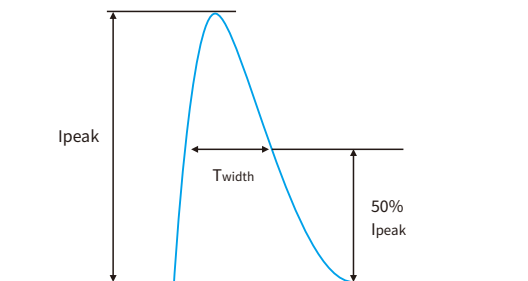

Remarks

- The number of drives mounted under different MCBs in the table is the maximum value. Please do not exceed this number during installation.
- Calculation uses typical values from ABB series S200 as a reference.
- Different brands and models of miniature circuit breakers, the number of drives mounted will be slightly different.
- If the ambient temperature of the MCB installation exceeds 30°C or multiple MCBs are installed side by side, the number of drives mounted will be reduced and the calculation needs to be recalculated.
- Electrician's usually consider Type B for household lighting and Type C for commercial lighting application.

Functions

Output short-circuit behaviour

- Output short-circuit will not damage the driver.
- After removing the short circuit fault, the driver will automatically resume output.

Output no-load operation

- Output no-load will not damage the driver.
- Please turn off the driver first if you need to connect the LED load.

Output overload protection

- The LED driver turns off the output if the output voltage range is exceeded. The output will be activated again after restart the LED driver .

Driver restart method

- There are two ways to restart the driver:
 - Through the AC input: disconnect the AC of the driver and power it again.
 - Through dimming interface.
 - 1-10V: first adjust the output voltage of the dimmer to 0.9V or below, then adjust it to 1V or above.

Insulation between circuits

Isolation	Input	Output	Case	DIM	PWM
Input	-	Double	Basic	Double	Double
Output	Double	-	Basic	-	-
Case	Basic	Basic	-	Basic	Basic

DIP-switch & output current

BK-BHL030-0750AM

Pin(w) typ.	Output			1	2	3	4
	Prated(w)	Irated(mA)	Voltage(Vdc)				
15.0	12.6	300	3-42	--	ON	ON	ON
17.0	14.7	350	3-42	ON	--	ON	ON
19.5	16.8	400	3-42	--	--	ON	ON
22.0	18.9	450	3-42	--	ON	--	ON
24.0	21.0	500	3-42	--	--	--	ON
26.5	23.1	550	3-42	ON	ON	ON	--
29.0	25.2	600	3-42	--	--	ON	--
31.0	27.3	650	3-42	--	ON	--	--
34.5	29.4	700	3-42	ON	--	--	--
34.5	30.0	750	★ 3-40	--	--	--	--

BK-BHL040-1000AM

Pin(w) typ.	Output			1	2	3	4
	Prated(w)	Irated(mA)	Voltage(Vdc)				
27.0	23.1	550	3-42	--	ON	ON	ON
29.0	25.2	600	3-42	ON	--	ON	ON
31.5	27.3	650	3-42	--	--	ON	ON
33.5	29.4	700	3-42	--	ON	--	ON
36.0	31.5	750	3-42	--	--	--	ON
38.5	33.6	800	3-42	ON	ON	ON	--
41.0	35.7	850	3-42	--	--	ON	--
43.0	37.8	900	3-42	--	ON	--	--
46.0	39.9	950	3-42	ON	--	--	--
46.0	40.0	1000	★ 3-40	--	--	--	--

BK-BHL050-1250AM

Pin(w) typ.	Output			1	2	3	4
	Prated(w)	Irated(mA)	Voltage(Vdc)				
38.0	33.6	800	3-42	--	ON	ON	ON
41.0	35.7	850	3-42	ON	--	ON	ON
43.0	37.8	900	3-42	--	--	ON	ON
46.0	39.9	950	3-42	--	ON	--	ON
48.0	42.0	1000	3-42	--	--	--	ON
50.0	44.1	1050	3-42	ON	ON	ON	--
53.0	46.2	1100	3-42	--	--	ON	--
55.0	48.3	1150	3-42	--	ON	--	--
57.0	49.8	1200	3-41.5	ON	--	--	--
57.0	50.0	1250	★ 3-40	--	--	--	--

BK-BHL060-1650AM

Pin(w) typ.	Output			1	2	3	4
	Prated(w)	Irated(mA)	Voltage(Vdc)				
57.5	50.4	1200	3-42	--	ON	ON	ON
59.5	52.5	1250	3-42	ON	--	ON	ON
61.5	54.6	1300	3-42	--	--	ON	ON
64.0	56.7	1350	3-42	--	ON	--	ON
66.5	58.8	1400	3-42	--	--	--	ON
67.5	59.5	1450	3-41	ON	ON	ON	--
68.0	60.0	1500	3-40	--	--	ON	--
68.0	59.7	1550	3-38.5	--	ON	--	--
68.0	60.0	1600	3-37.5	ON	--	--	--
67.5	59.4	1650	★ 3-36	--	--	--	--

BK-BHL070-2000AM

Pin(w) typ.	Output			1	2	3	4
	Prated(w)	Irated(mA)	Voltage(Vdc)				
63.0	54.6	1300	3-42	--	ON	ON	ON
68.0	58.8	1400	3-42	ON	--	ON	ON
70.0	60.9	1450	3-42	--	--	ON	ON
72.0	63.0	1500	3-42	--	ON	--	ON
74.0	65.1	1550	3-42	--	--	--	ON
79.0	69.3	1650	3-42	ON	ON	ON	--
79.0	69.7	1700	3-41	--	--	ON	--
80.0	70.2	1800	3-39	--	ON	--	--
80.0	70.3	1900	3-37	ON	--	--	--
80.0	70.0	2000	★ 3-35	--	--	--	--

Remarks:

- ★ It means that this item is the factory default current.
- It means that this channel is OFF.

Label

INPUT

AC/L/DC+
ACN/DC-
NC

BOKE Drivers Co., Ltd.
Address: 2nd and 3rd Floor, No.51, Xihuan 5th Road, South District, 528455 Zhongshan City, Guangdong, CHINA
www.bokedriver.com
MADE IN CHINA

Dimmable Constant Current LED Driver
MODEL: BK-BHL030-0750AM

INPUT: 200-240V ≈ 0/50/60Hz 0.25A Max. λ: 0.95
OUTPUT: 3-40V ≈ 750mA 30W 50VDC Max.

Other ratings see selection sheet
For LED Modules use only
www.bokedriver.com

tc:90°C
ta:60°C

OUTPUT

SEC wire prep. 0.5-1.5mm

LED+
LED-
DIM+
DIM-

DIM is connected to the SELV source
Do not connect LED+ LED- and DIM/DIM- wires

INPUT

AC/L/DC+
ACN/DC-
NC

BOKE Drivers Co., Ltd.
Address: 2nd and 3rd Floor, No.51, Xihuan 5th Road, South District, 528455 Zhongshan City, Guangdong, CHINA
www.bokedriver.com
MADE IN CHINA

Dimmable Constant Current LED Driver
MODEL: BK-BHL040-1000AM

INPUT: 200-240V ≈ 0/50/60Hz 0.3A Max. λ: 0.95
OUTPUT: 3-40V ≈ 1000mA 40W 50VDC Max.

Other ratings see selection sheet
For LED Modules use only
www.bokedriver.com

tc:90°C
ta:60°C

OUTPUT

SEC wire prep. 0.5-1.5mm

LED+
LED-
DIM+
DIM-

DIM is connected to the SELV source
Do not connect LED+ LED- and DIM/DIM- wires

INPUT

AC/L/DC+
ACN/DC-
NC

BOKE Drivers Co., Ltd.
Address: 2nd and 3rd Floor, No.51, Xihuan 5th Road, South District, 528455 Zhongshan City, Guangdong, CHINA
www.bokedriver.com
MADE IN CHINA

Dimmable Constant Current LED Driver
MODEL: BK-BHL050-1250AM

INPUT: 200-240V ≈ 0/50/60Hz 0.35A Max. λ: 0.95
OUTPUT: 3-40V ≈ 1250mA 50W 50VDC Max.

Other ratings see selection sheet
For LED Modules use only
www.bokedriver.com

tc:90°C
ta:60°C

OUTPUT

SEC wire prep. 0.5-1.5mm

LED+
LED-
DIM+
DIM-

DIM is connected to the SELV source
Do not connect LED+ LED- and DIM/DIM- wires

INPUT

AC/L/DC+
ACN/DC-
NC

BOKE Drivers Co., Ltd.
Address: 2nd and 3rd Floor, No.51, Xihuan 5th Road, South District, 528455 Zhongshan City, Guangdong, CHINA
www.bokedriver.com
MADE IN CHINA

Dimmable Constant Current LED Driver
MODEL: BK-BHL060-1650AM

INPUT: 200-240V ≈ 0/50/60Hz 0.5A Max. λ: 0.95
OUTPUT: 3-36V ≈ 1650mA 59.4W 50VDC Max.

Other ratings see selection sheet
For LED Modules use only

tc:90°C
ta:60°C

OUTPUT

SEC wire prep. 0.5-1.5mm

LED+
LED-
DIM+
DIM-

DIM is connected to the SELV source
Do not connect LED+ LED- and DIM/DIM- wires

INPUT

AC/L/DC+
ACN/DC-
NC

BOKE Drivers Co., Ltd.
Address: 2nd and 3rd Floor, No.51, Xihuan 5th Road, South District, 528455 Zhongshan City, Guangdong, CHINA
www.bokedriver.com
MADE IN CHINA

Dimmable Constant Current LED Driver
MODEL: BK-BHL070-2000AM

INPUT: 200-240V ≈ 0/50/60Hz 0.5A Max. λ: 0.95
OUTPUT: 3-35V ≈ 2000mA 70W 50VDC Max.

Other ratings see selection sheet
For LED Modules use only

tc:90°C
ta:60°C

OUTPUT

SEC wire prep. 0.5-1.5mm

LED+
LED-
DIM+
DIM-

DIM is connected to the SELV source
Do not connect LED+ LED- and DIM/DIM- wires

1-10V/10V PWM dimming application

Wiring diagram



Please DO NOT connect "DIM-" to "LED-" or "DIM+" to "LED+".

- | |
|---|
| 1.Supports isolated dimmers |
| 2.Passive dimmers need to beevaluated for testing |
| 3.Non-isolated dimmers are not supported |

Remarks

- Dimming interface characteristics: 0.9V and below are closed, 1V is the darkest, 10V is the brightest, 1-10V is the dimming range.
- The dimming interface distinguishes between positive and negative, DIM+ is positive, DIM- is negative, please do not reverse.
- Dimming interface does not support voltage access higher than 20V, otherwise it will cause damage to the internal components.
- When the dimming interface is open, the driver outputs the maximum current. When the interface is short-circuited, the current output is closed.
- When multiple synchronous dimming is required, the positive poles of the dimming interface of each driver are connected together, and the negative poles are connected together.
- Support passive dimmer or isolated active dimmer dimming, does not support non-isolated active dimmer dimming.
- In general, it is recommended that the number of mounted drives does not exceed 30pcs, and the wiring length does not exceed 100m.
- It is recommended that the dimming wires should not be lower than the 22AWG wire.
- Do not put the dimming wires with high voltage or interference sources. If it is unavoidable, please use the shielded wires.
- If you need a drive with 0-10V dimming characteristics, please contact BOKE.

Dimming curve

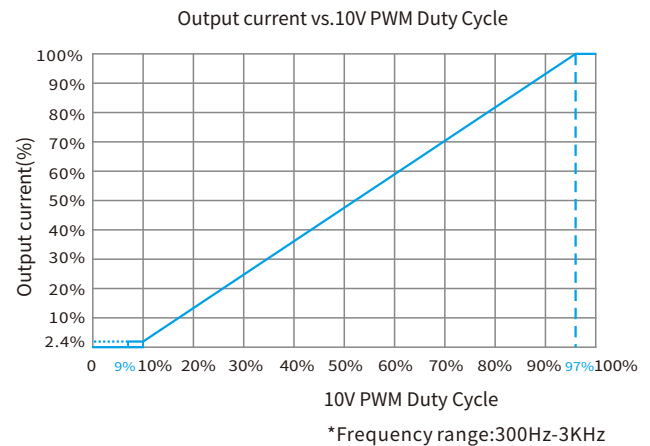
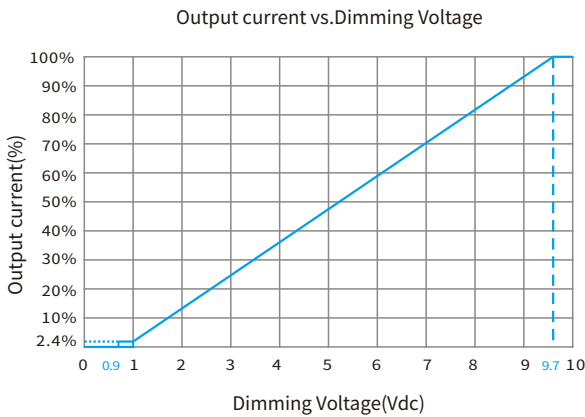

Optional accessories

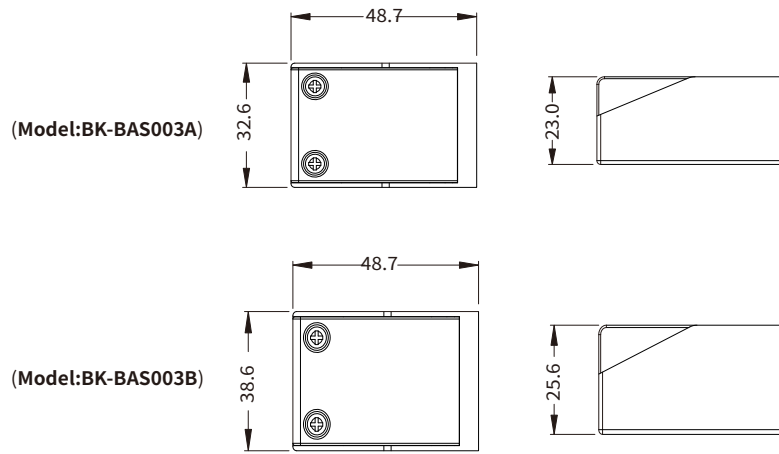
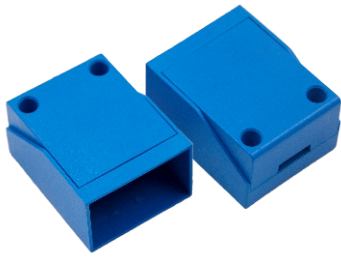

Remark: BK-BAS003A apply to BHL030, BHL040, BHL050, BHL060;
BK-BAS003B apply to BHL070.

Unit:mm

Installation diagram of accessories

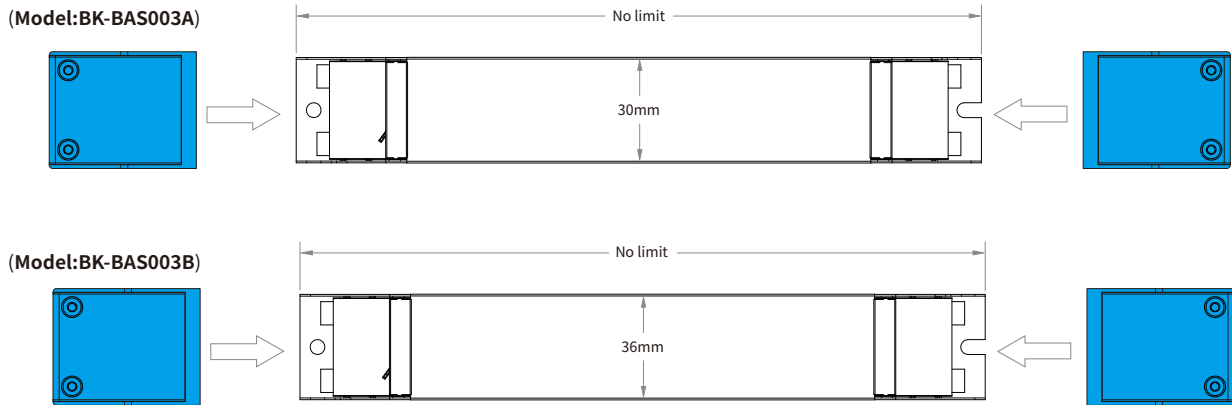

Mechanical Specification

Size(Excluding accessories)

Unit:mm

BHL030

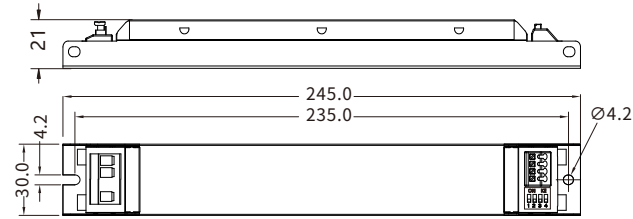

BHL040/BHL050

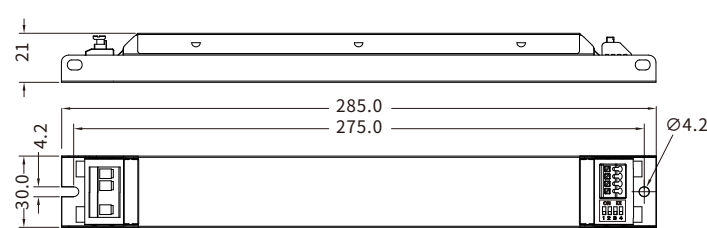

BHL060

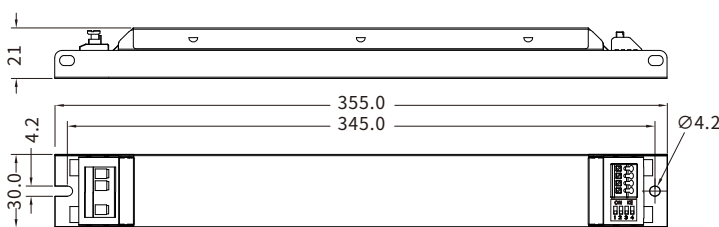

BHL080

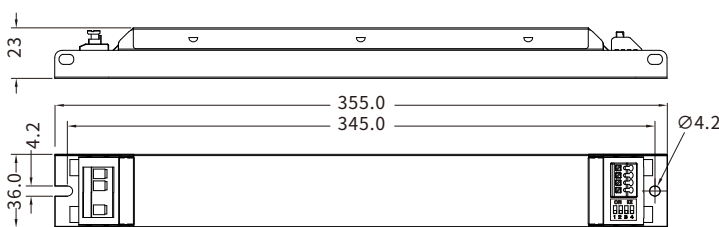

Mechanical Specification

Size(Include accessories)

Unit:mm

BHL030

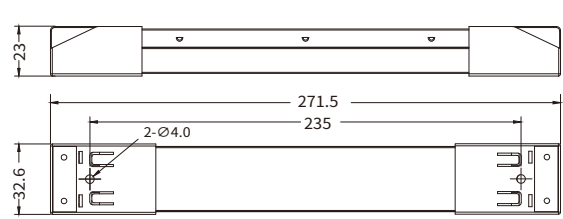

BHL040/BHL050

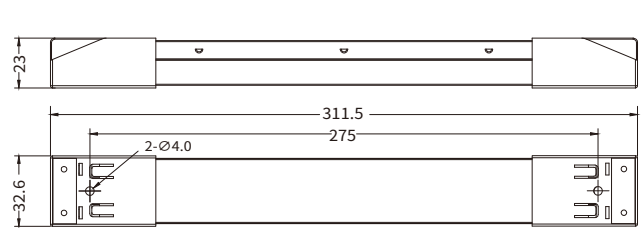

BHL060

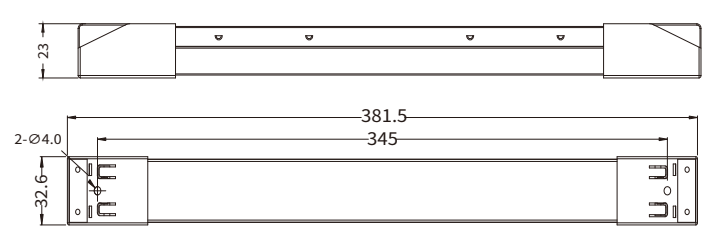

BHL080

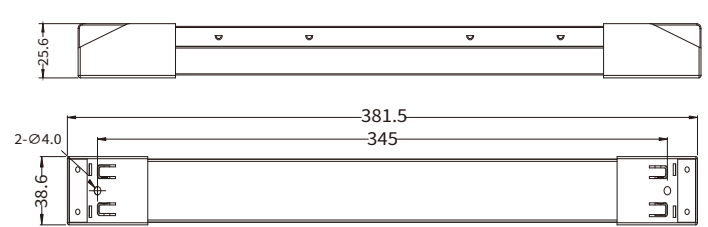

INPUT

Numbering	function	colour
1	ACL/DC+	orange
2	ACN/DC-	orange
3	NC	gray
4	FG	gray

Input wire

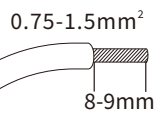

OUTPUT

Numbering	function	colour
1	LED+	red
2	LED-	black
3	DIM+	green
4	DIM-	black

Output wire

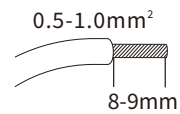

Installation note

Hot plug-in

- Hot plug-in is not supported due to residual output voltage of > 0 V.
- If a LED load is connected the device has to be restarted.
- Restart can be achieved by re-powering the driver or executing a on/off command (action) through the control interface (1-10V)

Wiring guidelines

- All connections must be kept as short as possible to ensure good EMI behaviour.
- Mains leads should be kept apart from LED Driver and other leads (ideally 5 - 10 cm distance)
- Max. length of output wires is 2 m.
- Incorrect wiring can damage LED modules.

Mounting screw specifications and torque

- Max. torque at the clamping screw: 0.5 Nm / M4

Replace LED module

1. Mains off
2. Remove LED module
3. Wait for 5 seconds
4. Connect LED module again

Installation requirements

- The driver should be installed in a dry, acid-free, oil-free, fat-free environment.
- The installation ambient temperature of the drive shall not exceed the value of Ta at any time.
- The temperature of the mounting surface of the driver should be lower than 40°C
- If the driver is used externally (it needs to be used with the accessories), the installation of the driver should also meet the following conditions:
 - 1.The driver should be a certain distance between the drivers, as shown in Figure 1.
 - 2.The driver keeps a certain distance from surrounding objects, as shown in Figure 2.
- The driver should keep a certain distance from the heating stuff (such as the luminaire radiator).

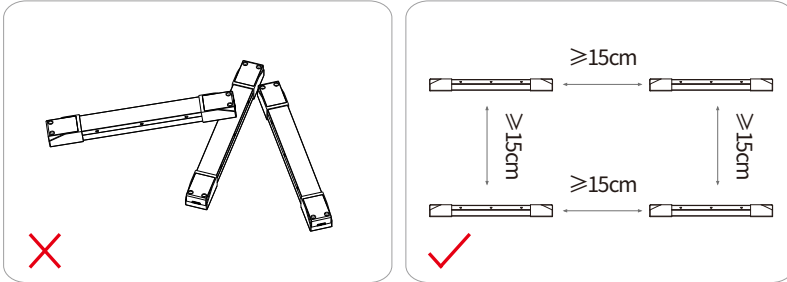

Figure 1

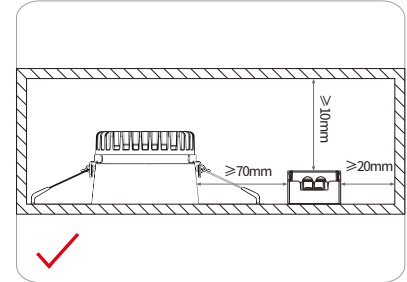
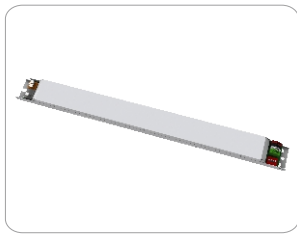
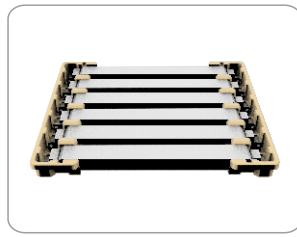

Figure 2

Packaging



Product



Paper tray



7pcs*6layer=42pcs/CIN
 7pcs*5layer=35pcs/CIN
 7pcs*4layer=28pcs/CIN
 6pcs*4layer=24pcs/CIN

Model	Product size	Weight	Paper tray	Carton size	Qty/carton	N.W	G.W
BHL030	L245*W30*H21mm	171g	L340*W75*H29mm	L355*W285*H205mm	42pcs	7.18KG	8.48KG
BHL040	L285*W30*H21mm	206g	L340*W75*H29mm	L355*W325*H170mm	35pcs	7.21KG	8.51KG
BHL050	L285*W30*H21mm	229g	L340*W75*H29mm	L355*W325*H170mm	35pcs	8.02KG	9.32KG
BHL060	L355*W30*H21mm	293g	L340*W75*H29mm	L395*W355*H140mm	28pcs	8.21KG	9.40KG
BHL070	L355*W36*H23mm	381g	L340*W75*H33mm	L395*W355*H160mm	24pcs	9.15KG	10.3KG

Accessories

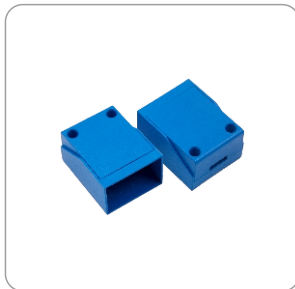

End cap + screws



100 sets/CIN

Model	Product size	Weight	Carton size	Qty/carton	N.W	G.W
BAS003A	L48.7*W32.6*H23mm	22g	L450*W350*H180mm	100 sets	2.2kg	2.7kg
BAS003B	L48.7*W38.6*H25.6mm	27g	L450*W350*H180mm	100 sets	2.7kg	3.2kg

Additional information

1. The life and MTBF of the product are for reference only, and do not represent a warranty statement.
2. For more information, please send an email to info@bokedriver.com.