

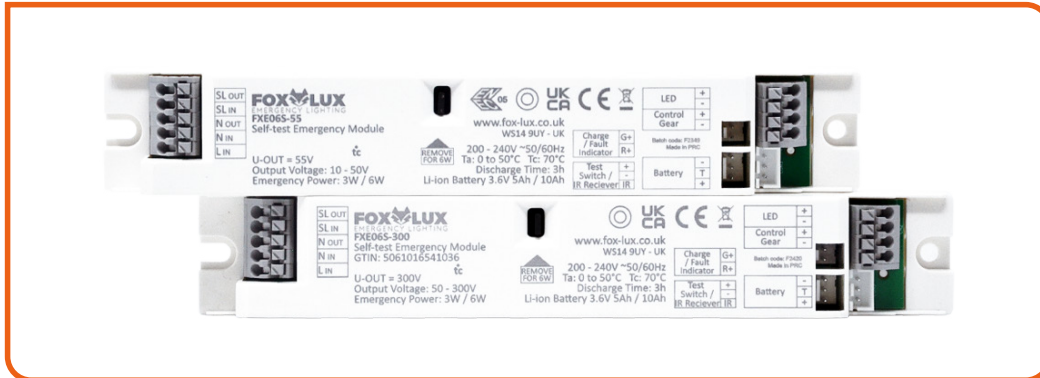

FXE06 CONVERSION MODULE



VARIANTS AVAILABLE: SELF-TEST / DALI-2

- Selectable 3W or 6W emergency output
- 8 year warranty including battery
- For LED arrays with a forward voltage of 10-300V
- Remote control compatible with optional receiver (IR-R)
- Compatible with LiteIP
- Pre-commissioning feature via REM-E1



Part Number	Description	Output Voltage Range	EM Out.
FXE06S-55	Conversion Module - Self-test	10-50V	3W / 6W
FXE06S-300	Conversion Module - Self-test	50-300V	3W / 6W
FXE06DL-55	Conversion Module - DALI-2	10-50V	3W / 6W
FXE06DL-300	Conversion Module - DALI-2	50-300V	3W / 6W

NOTE: Self-test conversion modules are configured to manual test mode by default. If self-test mode is required, it should be activated via remote control.

DIMENSIONS

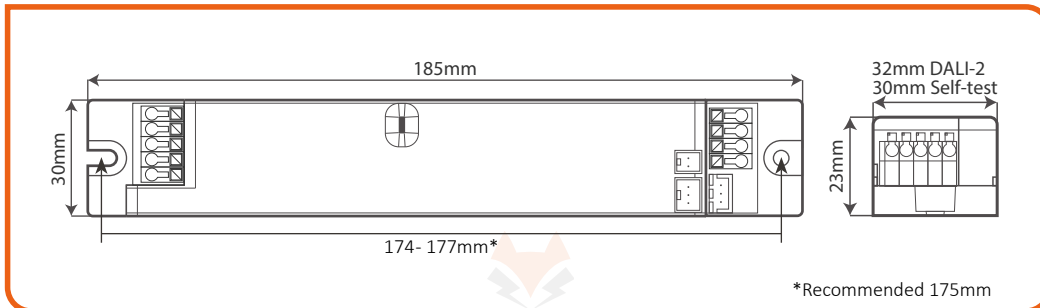

WIRING DIAGRAM

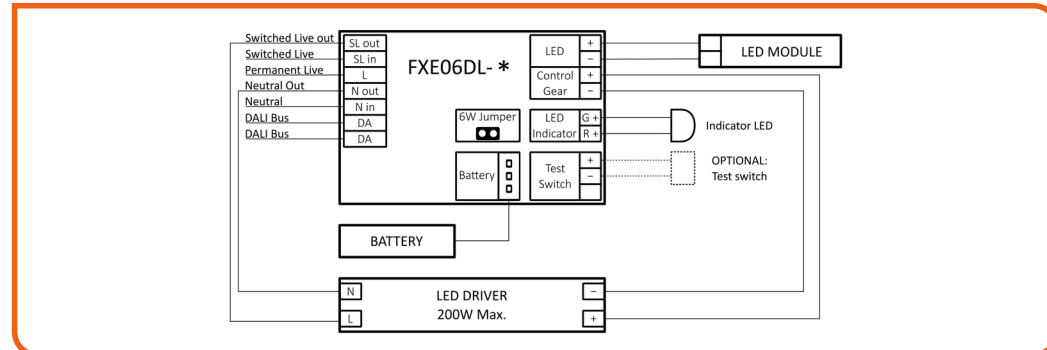
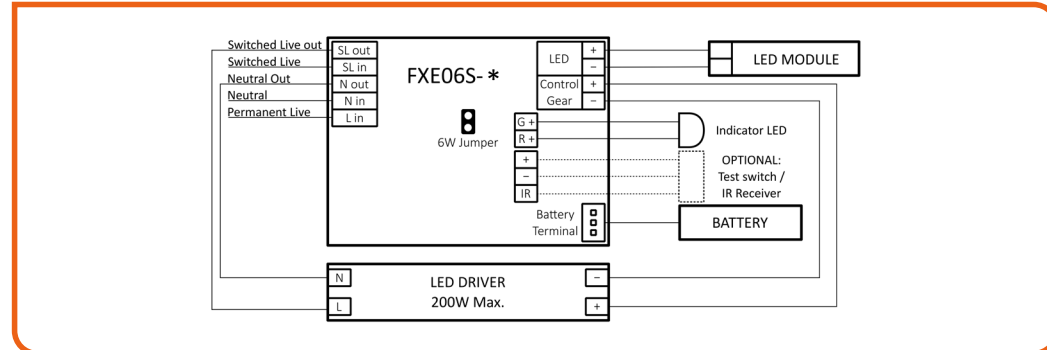

Technical Data	FXE06S-55	FXE06S-300	FXE06DL-55	FXE06DL-300
Rated Supply Voltage	220-240V AC	220-240V AC	220-240V AC	220-240V AC
Mains Frequency	50 / 60 Hz	50 / 60 Hz	50 / 60 Hz	50 / 60 Hz
Max. Power Consumption	5W	5W	5W	5W
Standby Power	<0.9W	<0.9W	<0.8W	<0.9W
Emergency Output Power	3W / 6W selectable	3W / 6W selectable	3W / 6W selectable	3W / 6W selectable
LED Forward Voltage Range	10 to 50V	50 to 300V	10 to 50V	50 to 300V
Max. Output Voltage	60V DC	310V DC	60V DC	310V DC
Rated Emergency Duration	3 hrs*	3 hrs*	> 3 hrs	> 3 hrs
Battery Charge Time	8 hrs (Initial up to 16 hrs)	8 hrs (Initial up to 16 hrs)	<20 hrs at 3W / <40 hrs at 6W	
Operational Temperature	0°C to 50°C	0°C to 50°C	0°C to 50°C	0°C to 50°C
Max. Case Temp.	70°C	70°C	70°C	70°C
Insulation Class	Reinforced	Reinforced	Reinforced	Reinforced
SELV	Yes	No	Yes	No
Battery Type	2 x 18650 Li-ion 3.6V 5.0Ah / 4 x 18650 Li-ion 3.6V 10.0Ah		2 x 18650 Li-ion 3.6V 5.0Ah / 4 x 18650 Li-ion 3.6V 10.0Ah	
Battery Code	FXC3.6-5000-D300 / FXC3.6-10000-D300		FXC3.6-5000-D300 / FXC3.6-10000-D300	

*To optimise long-term battery performance, the module will operate a luminaire for 3 hours before automatically shutting down.

Materials		LED Driver Compatibility	FXE06*-55	FXE06*-300
Housing	Polycarbonate	Max. Output Current of LED Driver	5A	2A
Finish	Matt	Max. Inrush Current of LED Driver	60A	60A
Colour	White	Max. Load of LED Driver	200W	200W

*Information for self-test or DALI-2

Logistics Info.	FXE06S-55	FXE06S-300	FXE06DL-55	FXE06DL-300
Product Dimensions	185 x 30 x 23mm	185 x 30 x 23mm	185 x 32 x 23mm	185 x 32 x 23mm
Net Weight	0.07kg	0.07kg	0.07kg	0.07kg
Box Dimensions	360 x 112 x 70mm	360 x 112 x 70mm	360 x 112 x 70mm	360 x 112 x 70mm
Gross Weight	0.07kg	0.07kg	0.09kg	0.09kg
Box Qty	10pcs	10pcs	16pcs	16pcs
Carton Dimensions	340 x 210 x 290mm	340 x 210 x 290mm	340 x 210 x 290mm	340 x 210 x 290mm
Carton Weight	8.5kg	8.5kg	9.75kg	9.75kg
Commodity Code	8504318050	8504318050	8504318050	8504318050

SELF-TEST

Indicator LED Status

GREEN LED	RED LED	STATUS
On	Off	Standby
Slow Flash	Off	Charging
Fast Flash	Off	Function test or duration test in progress
Off	On	Battery disconnected / Duration test failed
Off	Fast Flash	Battery temperature out of operational range
Off	Slow Flash	Light source faulty, disconnected or incompatible.

DALI-2

Indicator LED Status

GREEN LED	RED LED	STATUS
On	Off	Standby
Slow Flash	Off	Duration test in progress
Fast Flash	Off	Function test in progress
Off	On	Battery temperature out of operational range
Off	Slow Flash	Battery disconnected / Duration test failed
Off	Fast Flash	Battery low voltage.
Off	Off	Emergency function in operation
Alternating Green > Red > Green...		DALI-2 identifying code

LED DRIVE CURRENT IN EMERGENCY MODE

Data provided as a guide only.
Data will vary based on type of LED chip and the LED array configuration.

FXE06S-55-3

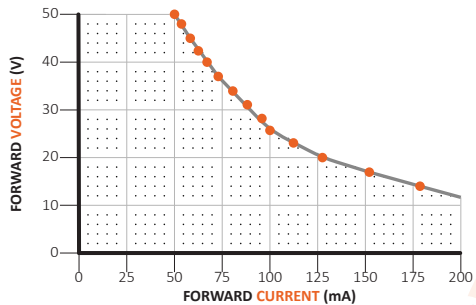

FXE06S-55-6

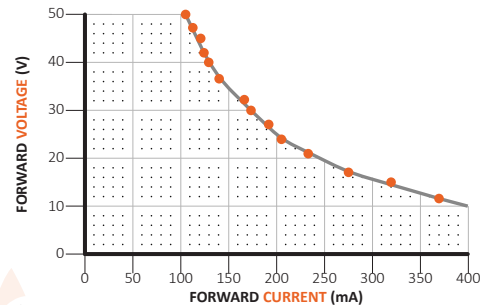

FXE06S-300-3

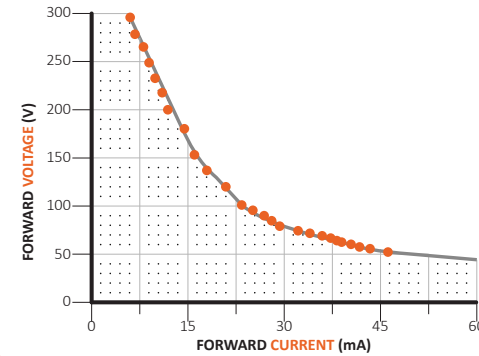

FXE06S-300-6

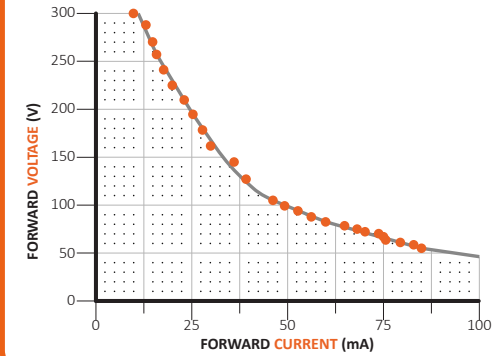

FXE06DL-55-3

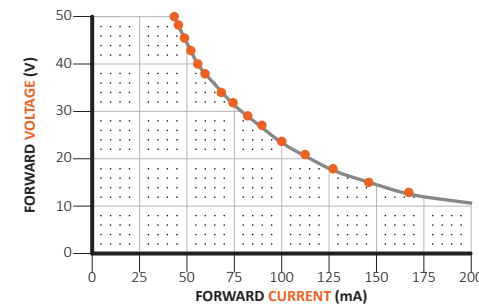

FXE06DL-55-6

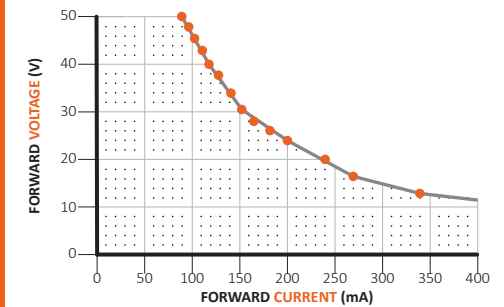

FXE06DL-300-3

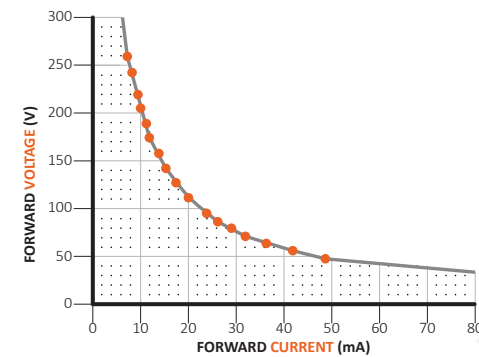

FXE06DL-300-6

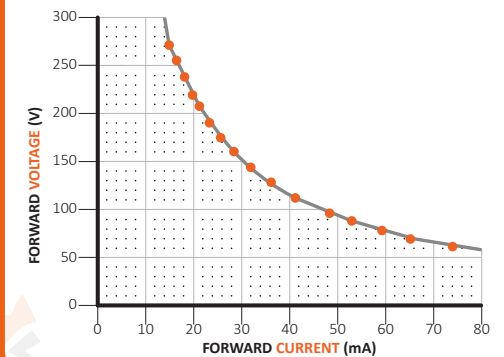

ACCESSORIES

2-CELL 5.0Ah LI-ION BATTERY FOR FXE06*



FXC3.6-5000-D300	
Dimension	160 x 21 x 21mm
Battery Type	2 x 18650 Li-ion 3.6V 5.0Ah
Cable Length	300mm
Gross Weight	0.10kg
Commodity Code	85065010

- 5000mAh battery used with FXE06 in 3W configuration.

RED/GREEN LED INDICATOR FOR FXE06*



LED1000RG-C-06	
Dimensions	5mmØ (LED)
Mounting Hole Size	7mmØ
Cable Length	1000mm cable
Gross Weight	0.02kg
Commodity Code	85395200

- Red / green LED indicator with 1000mm wire.

4-CELL 10.0Ah LI-ION BATTERY FOR FXE06*



FXC3.6-10000-D300	
Dimension	160 x 21 x 42mm
Battery Type	4 x 18650 Li-ion 3.6V 10.0Ah
Cable Length	300mm
Gross Weight	0.20kg
Commodity Code	85065010

- 10000mAh battery used with FXE06 in 6W configuration.

RECESSING BEZEL FOR LED INDICATOR / IR-R

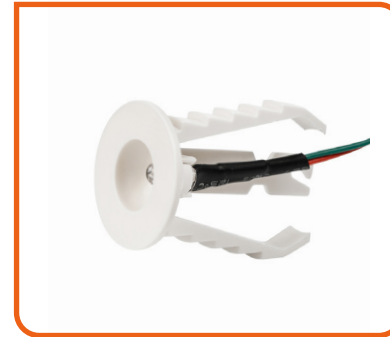

BEZ01	
Dimensions	27Ø x 46mm
Cutout Size	22mmØ
Gross Weight	< 0.01kg
Commodity Code	94059200

- Recessing bezel for use with LED indicators and infrared receivers.

RED/GREEN LED INDICATOR FOR FXE06*



LED600RG-C-06	
Dimensions	5mmØ (LED)
Mounting Hole Size	7mmØ
Cable Length	600mm cable
Gross Weight	0.02kg
Commodity Code	85395200

- Red / green LED indicator with 600mm wire.

INFRARED RECEIVER



IR-R	
Dimensions	5mmØ (LED)
Mounting Hole Size	7mmØ
Cable Length	600mm
Gross Weight	0.02kg
Commodity Code	85395200

- Infrared receiver required to allow compatibility with REM-E1 remote control. (NOT COMPATIBLE WITH DALI-2 PRODUCTS.)

REMOTE CONTROL



REM-E1	
Dimensions	117 x 38 x 13mm
Gross Weight	0.03kg
Commodity Code	85437003
<ul style="list-style-type: none"> ● Infrared remote control for all Fox Lux self-test luminaires, modules and remote packs. ● Batteries not included, requires 2 x AAA. <p><i>(NOT COMPATIBLE WITH DALI-2 PRODUCTS.)</i></p>	

BATTERY WIRE EXTENSION FOR FXE06*



FXE06-EXT	
Cable Length	300mm
Gross Weight	0.01kg
Commodity Code	94059900
<ul style="list-style-type: none"> ● Battery extension cable, allowing for splice connection to litelP nodes. 	

TEST BUTTON FOR FXE06*



TB04	
Dimensions	9mmØ x 20mm
Mounting Hole Size	7mmØ
Cable Length	600mm
Gross Weight	0.01kg
Commodity Code	94059900
<ul style="list-style-type: none"> ● Optional manual test button for FXE06 modules. 	

LITEIP NODE CONNECTOR FOR FXE06*



LIPCON	
Cable Length	600mm
Gross Weight	< 0.01kg
Commodity Code	94059900
<ul style="list-style-type: none"> ● Indicator LED wiring loom for connecting FXE06 modules to litelP nodes. 	

