



FXMB MINI IP65 BULKHEAD



- Maintained or non-maintained
- Legend pack included 18m viewing distance
- 16mm entry points. IP65 cable gland included.
- 8 year warranty including battery
- Remote control compatible
- Pre-commissioning feature via REM-E1



Part Number	Description	Output	Optic	Beam Angle
FXMBS-M-3	IP65 Mini Bulkhead - Self-test	170lm	Reeded Diffuser	140°

NOTE: Self-test luminaires are configured to manual test mode by default. If self-test mode is required, it should be activated via remote control.

DIMENSIONS

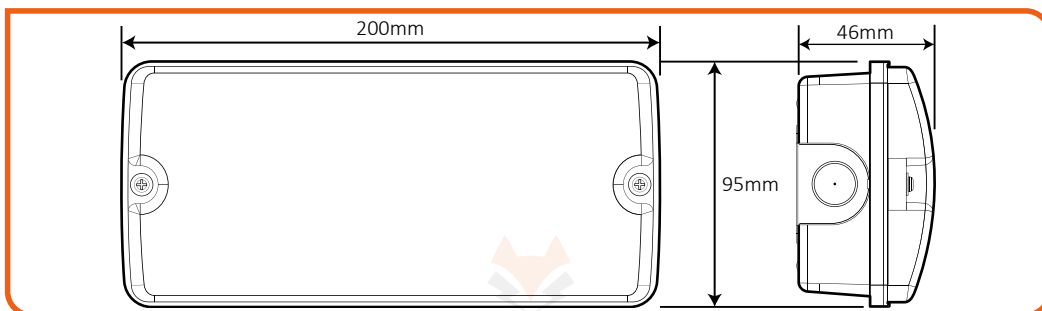

Technical Data	FXMB
Rated Supply Voltage	220-240V AC
Mains Frequency	50 / 60 Hz
Max. Power Consumption	5W
Standby Power	<0.5W
Emergency Output Power	1.5W
Rated Emergency Duration	3 hrs*
Battery Charge Time	8 hrs (Initial up to 16 hrs)
Operational Temperature	0°C to 40°C
Storage Temperature	0°C to 50°C
Insulation Class	II
Ingress Protection	IP65
Impact Protection	IK10
Battery Type	1 x 18650 Li-ion 3.6V 2.5Ah
Battery Code	FXC3.6-2500-B80

*To optimise long-term battery performance, the luminaire will operate for 3 hours before automatically shutting down.

Logistics Information	FXMB
Product Dimensions	200 x 46 x 95mm
Net Weight	0.26kg
Box Dimensions	205 x 53 x 100mm
Gross Weight	0.31kg
Box Qty	36pcs
Carton Dimensions	430 x 320 x 345mm
Carton Weight	12.05kg
Commodity Code	9405423100

Materials	
Housing	Polycarbonate
Finish	Matt
Colour	White
Screws	Nickel Steel

LED Light Source	
Type	2835
Colour Temp.	4000K
CRI	>80
LED Lifetime	50,000 hrs

SELF-TEST

Indicator LED Guide		
GREEN LED	RED LED	STATUS
On	Off	Standby
Slow Flash	Off	Charging
Fast Flash	Off	Function test or duration Test in progress
Off	On	Battery disconnected / Duration test failed
Slow Flash	Slow Flash	Battery temp. out of operational range
Off	Slow Flash	Light source fault

ACCESSORIES

REMOTE CONTROL



REM-E1

Dimensions	117 x 38 x 13mm
Gross Weight	0.03kg
Commodity Code	85437003

- Infrared remote control for all Fox Lux self-test luminaires, modules and remote packs.
- Batteries not included, requires 2 x AAA.
(NOT COMPATIBLE WITH DALI-2 PRODUCTS.)

