

## FXS01C-E MICROWAVE SENSOR

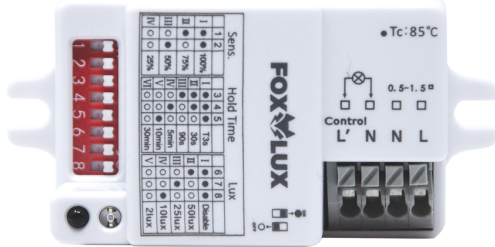

### FEATURES

- Designed for built-in applications
- Daylight monitoring with dual photocell
- Settings via dip switches

### KEY ELEMENTS

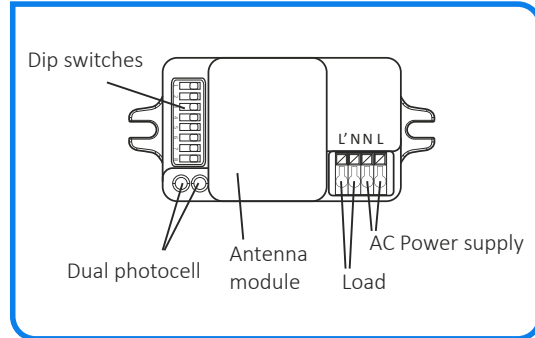

### DIMENSIONS

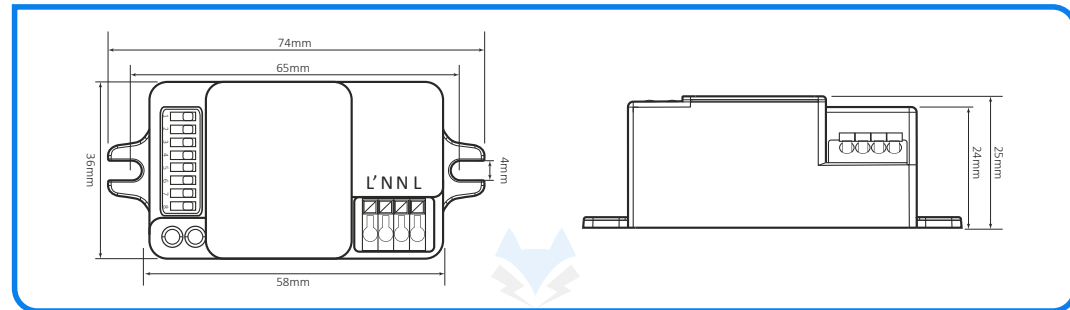

### Technical Data

Operating Voltage	220-240V AC 50-60Hz
Rated Load	400W
Standby Power	<0.5W
Sensor Technology	Microwave
Mounting Height	3-6m
Detection Radius	Max. 6m
Operating Temperature	-20°C to 70°C
IP Rating	IP20

### Logistics Information

Product Dimensions	74 x 36 x 25mm
Net Weight	0.04kg
Box Dimensions	N/A
Gross Weight	0.04kg
Carton Qty	240pcs
Carton Dimensions	450 x 300 x 230mm
Carton Weight	10.50kg
Commodity Code	8536500090

### Materials

Housing	Polycarbonate
Finish	Matt
Colour	White

### WIRING

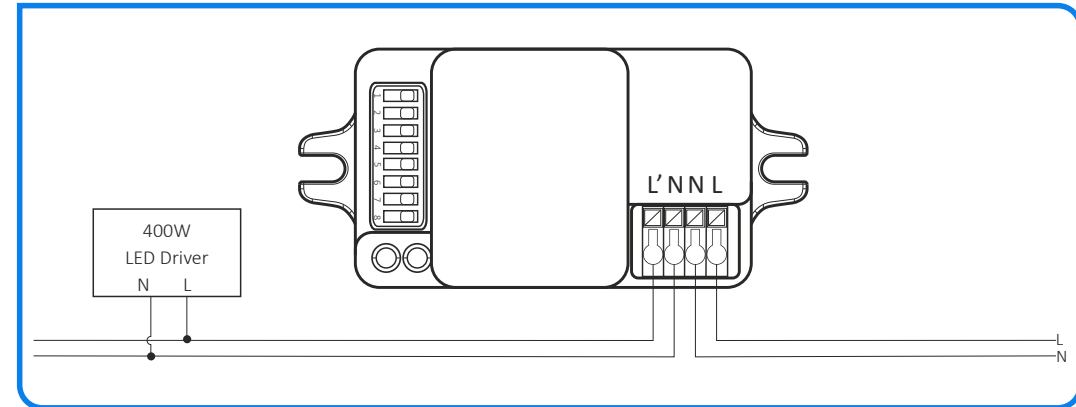

### DETECTION

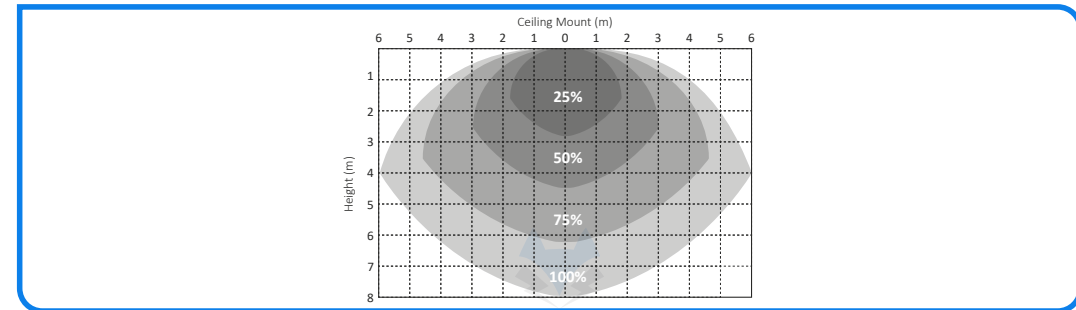

## DAYLIGHT MONITORING

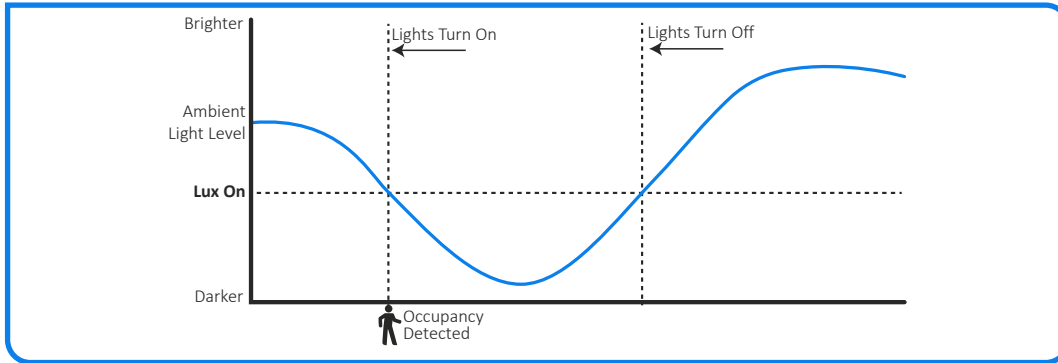

## DIP SWITCH SETTINGS

This sensor can be set up with dip switches found on the sensor. Each section controls different settings depending on the combination of switches. Graphic to the right displays the full row of dip switches and which position indicates on or off.

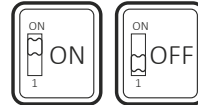
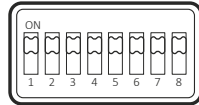

### Sensitivity - Switch 1 / 2

The sensitivity can be adjusted between 25% (low sensitivity) and 100% (high sensitivity)



#### 1 2 Sensitivity

On	On	100%
On	Off	75%
Off	On	50%
Off	Off	25%

### Hold Time - Switch 3 / 4 / 5

The sensor will continue to provide power for a duration of time after the last motion was detected.

If any motion is detected within the set duration time the sensor will reset the timer.

This duration can be adjusted from 30 seconds up to 30 minutes.

*\*Test Mode: When hold-time is set at 3s, the sensor enters test mode in order to select the desired detection range/sensitivity. In this mode the daylight sensors are disabled so when there is no motion the luminaire stays off. When there is motion detected the sensor cycles 3s on and 2s off.*



#### 3 4 5 Hold Time

On	On	On	T3s*
On	On	Off	30s
On	Off	Off	90s
Off	On	Off	5min
Off	Off	On	10min
Off	Off	Off	30min

### Lux Control - Switch 6 / 7 / 8

The Sensor includes a photocell which can be used to limit the operation depending on the ambient light level.

When set to 50 lux or below the sensor will only operate during the hours of darkness.

When set to disable the sensor will operate regardless of the ambient light levels.



#### 6 7 8 Lux

On	On	On	Disable
On	Off	Off	50lux
Off	On	Off	25lux
Off	Off	On	10lux
Off	Off	Off	2lux

