

FXS05D4 DALI-2 REMOTE HEAD MICROWAVE SENSOR

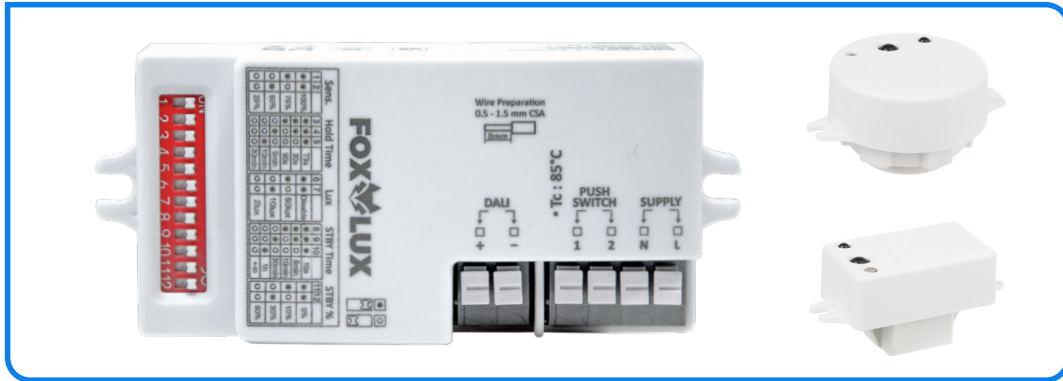

FEATURES

- Designed for built-in applications
- Daylight monitoring with onboard photocell
- Settings via DALI configuration software
- Alternatively, sensitivity settings via remote control
- Sensor power supply via mains supply
- Switchable DALI-2 Power supply built in
- Individual / group addressing

KEY ELEMENTS

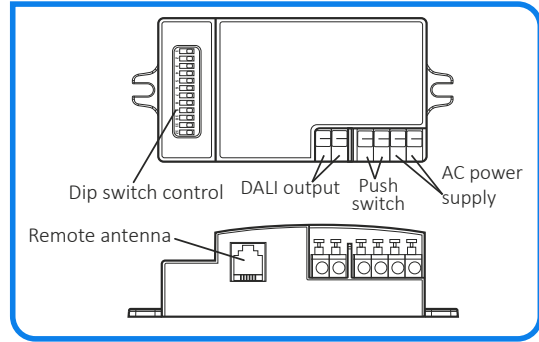

DIMENSIONS

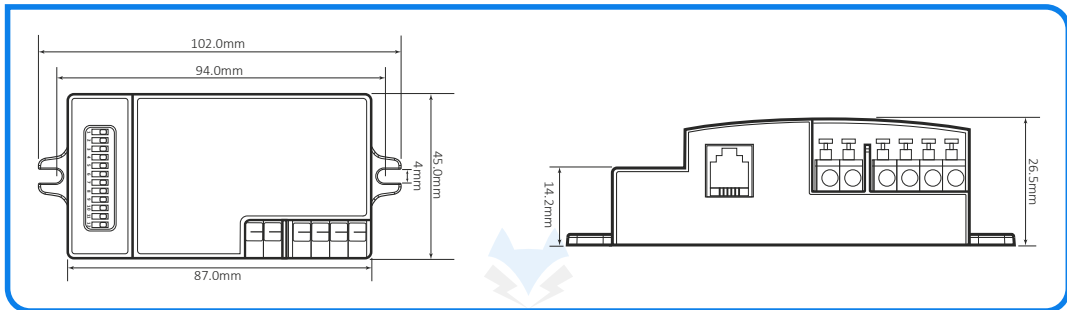

Technical Data

Operating Voltage	220-240V AC 50-60Hz
DALI-2 output	Max. 30 devices, max. 60mA
Standby Power	<1W
Sensor Technology	Microwave
Mounting Height	3-6m
Detection Radius	Max. 6m
Operating Temperature	-20°C to 70°C
IP Rating	IP20

Logistics Information

Product Dimensions	102 x 27 x 45mm
Net Weight	0.07kg
Box Dimensions	N/A
Gross Weight	0.07kg
Carton Qty	120pcs
Carton Dimensions	450 x 300 x 230mm
Carton Weight	9.20kg
Commodity Code	8536500090

Materials

Housing	Polycarbonate
Finish	Matt
Colour	White

REMOTE CONTROL OR DIP SWITCH SETTINGS

When used without a front end control system, the settings can be adjusted directly via remote control or dip switches. The paired remote control for this sensor is REM-S22. See separate data sheet for further details.

WIRING

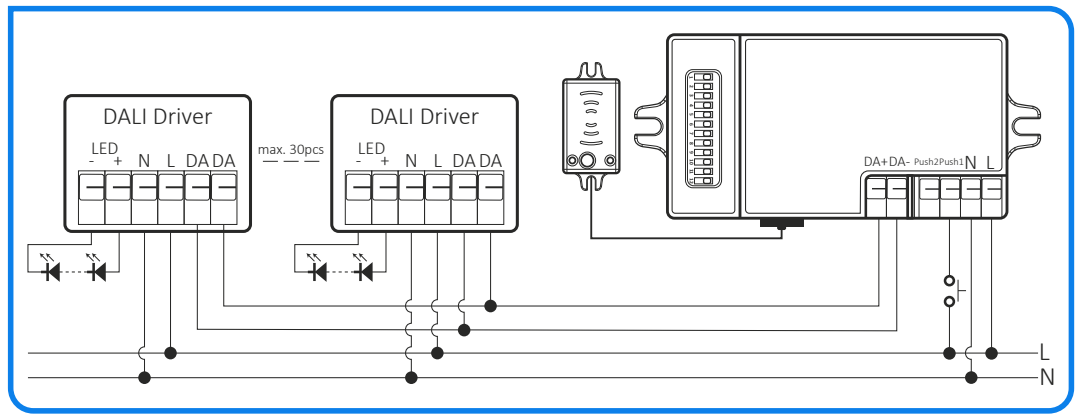

DETECTION DIAGRAM

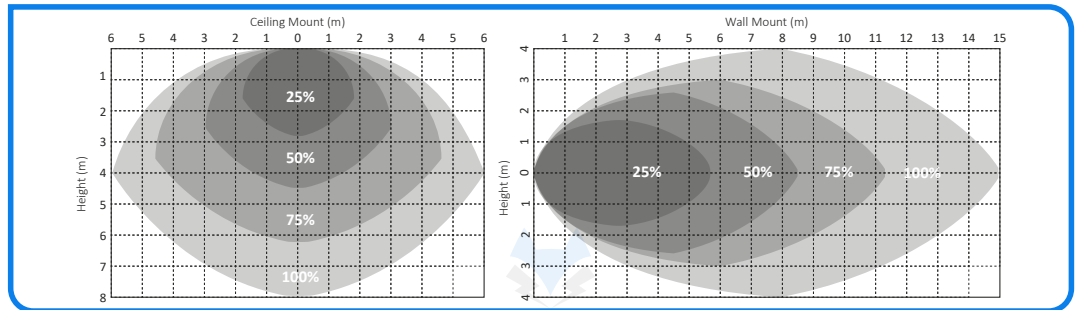

DATA SHEET

Address	Description	Factory default value	Reset Value	Range of validity	Memory Type
0x00	Address of last accessible memory location	0x1F	no change	0x1F	ROM
0x01	Indicator byte	0x8C	no change	0x8C	ROM
0x02	Memory bank 2 lock byte. Lockable bytes in the memory bank shall be read-only while the lock byte has a value different from 0x55	0xFF	0xFF		RAM
0x03	flag	0x00	0x00	0x00	RAM
0x04	mode	0x00	0x00	0x00	NVM(lockable)
0x05	HF sensitivity	100% (0x64)	0x64 (100%)	0x64 (100%)	NVM(lockable)
		75% (0x4B)			
		50% (0x32)			
		25% (0x19)			
0x06	T1 level	0xFE	0xFE (100%)	[0, 254]	NVM(lockable)
0x07	T2 level	0xAA	0xAA (10%)	[0, 254]	NVM(lockable)
0x08	T1 time (LSB)	0x5A	0x5A (90s)	[1, 65535(+ ∞)]	NVM(lockable)
0x09	T1 time (MSB)	0x00	0x00		NVM(lockable)
0x0A	T2 time (LSB)	0x2C	0x2C (5min)	[0, 65535(+ ∞)]	NVM(lockable)
0x0B	T2 time (MSB)	0x01	0x01		NVM(lockable)
0x0C	Lux level (LSB)	0xFF	0xFF (disable)	[1, 1000lux], 65535(disable)	NVM(lockable)
0x0D	Lux level (MSB)	0xFF	0xFF		NVM(lockable)
0x0E	Send data way	0x00	0x00 (default factory setting)	0x00, 0x01	NVM(lockable)
0x0F	Send data address method	0x00	0x00 (Broadcast)	0x00 (Broadcast)	NVM(lockable)
				0x01 (Short addressing)	
				0x02 (Group addressing)	
				0x03 (Multi-groups addressing)	
				Other: 0x00(Broadcast)	
0x10	Send data address value	0x00	0x00	Location 0x0D=1, [0, 63]; Location 0x0D=2, [0, 15]	NVM(lockable)
0x11	T1 scene	0x00	0x00	[0, 15]	NVM(lockable)
0x12	T2 scene	0x01	0x01	[0, 15]	NVM(lockable)
0x13	Receive occupancy sensor type	0x9F	0x9F	x00x xxxxb	NVM(lockable)
0x14	Receive occupancy sensor short address	0x00	0x00	[0, 63]	NVM(lockable)
0x15	Receive occupancy sensor instance number byte0 (LSB)	0xFF	0xFF	[0, 0xFFFFFFFF]	NVM(lockable)
0x16	Receive occupancy sensor instance number byte1	0xFF	0xFF		NVM(lockable)
0x17	Receive occupancy sensor instance number byte2	0xFF	0xFF		NVM(lockable)
0x18	Receive occupancy sensor instance number byte3 (MSB)	0xFF	0xFF		NVM(lockable)
0x19	Receive occupancy sensor instance group byte0 (LSB)	0xFF	0xFF	[0, 0xFFFFFFFF]	NVM(lockable)
0x1A	Receive occupancy sensor instance group byte1	0xFF	0xFF		NVM(lockable)
0x1B	Receive occupancy sensor instance group byte2	0xFF	0xFF		NVM(lockable)
0x1C	Receive occupancy sensor instance group byte3 (MSB)	0xFF	0xFF		NVM(lockable)
0x1D	Dip status (MSB)	0xFF	0xFF	0xFF	ROM
0x1E	Dip status (MSB)	0xFF	0xFF	0xFF	ROM
0x1F	DALI bus power supply	0x01	no change	on=0x01, off=0x00	NVM(lockable)

LSB: Least Significant Byte.
MSB: Most Significant Byte.
Range of values: [lowest, highest]

All numbers used in this document are decimal numbers unless otherwise noted. Hexadecimal numbers are given in the format 0xVV, where VV is the value. Binary numbers are given in the format XXXXXXXxb or in the format XXXX XXXX, where X is 0 or 1; "x" in binary numbers means "don't care"

Flag: Synchronize the parameters of remote control, and not recommended for normal use.
(1) Bit0: setting to 1, the device restores to "RESET" setting of the remote control, and automatically clear bit0 after execution.
(2) Bit1-7: reservation

Mode: Synchronize the parameters of remote control, and not recommended for normal use. Setting the sensor's working mode
(1) 0x00: AUTO mode
(2) 0x01: PERMANENT OFF mode
(3) 0x02: PERMANENT ON mode

Detection range:
Sensitivity: 100% (0x64), 75% (0x4B), 50% (0x32), 25% (0x19).

T1 level:
This is the preset max. brightness of the fixture after motion detected. The brightness that the sensor enters into T1 by DAPC, the default factory setting is 0xFE.

T2 level:
This is the dimmed low light level you would like to have after the hold time in the absence of people. The brightness that the sensor enters into T2 by DAPC, the default factory setting is 0xFE.

T1 time:
T1 time is Hold-time that means the time period to keep the lamp on T1 level after motion detected. T1 time=65535 (0xFFFF)[+ ∞], means bi-level dimming control, the fixture never enters into T2 level.

T2 time:
This is the time period that the lamp remains at T2 level before it is completely switched off in the long absence of people. When T2 time=65535 (0xFFFF) [+ ∞], means bi-level dimming control, the fixture never switch off.

Lux level:
Lux level means the daylight threshold to enable or disable the sensor function. Lux level=65535 (0xFFFF)[Disable], means the sensor always, even during daylight.

Send data way:
The sensor sends the signals of control gears, and the details are as below:
0x00: DAPC (direct arc power control)- default factory setting;
0x01: Recall Scene Command- Recall scene value is T1 scene (0x0F) and scene (0x10) in memory bank;
Other: same function as 0x00

Send data address method:
This is the method of device addressing used by the transmitter, adapts different way to send DAPC command or recall scene based on required value.

0x03: Multi-groups addressing, can control the groups the sensor enters into, then send the multi-group control instances one time, max. 16 groups

Send data address value:
(1) Send data address method=0x01 [0, 63], default setting is 63 when data> 63;
(2) Send data address method=0x02 [0, 15], default setting is 15 when data> 15;

T1 Scene:
The sensor sends the value of scene instance [0, 15] under T1 status, default setting is 15 when data> 15

T2 Scene:
The sensor sends the value of scene instance [0, 15] under T2 status, default setting is 15 when data> 15;

Receive occupancy sensor type:
The sensor receive the signal other sensors sent (24-bit event message frame).

- (1) Bit7: event message enable
- (2) Bit4: instance groups + instance types (event scheme 4)
- (3) Bit3: device groups + instance types (event scheme 3)
- (4) Bit2: short addresses + instance numbers (event scheme 2)
- (5) Bit1: short addresses + instance types (event scheme 1)
- (6) Bit0: instance types + instance numbers (event scheme 0)
- (7) Other bit: reservation

Receive occupancy sensor short address:
Receive occupancy sensor type [bit2], the sensor can receive the equivalent signal of occupancy sensor short address. Range of validity [0, 63], default setting is 63 when data> 63;

Receive occupancy sensor instance number:
Bit0-Bit31: each bit corresponds to instance number, e.g. bit is 1, means that the sensor can receive the signal of the instance number (bit is 1).

For example: receive occupancy sensor instance number=0x00000003, Bit0=1 & Bit1=1, means that receives occupancy sensor signal of the sensor whose instance number is 0 and 1.

Receive occupancy sensor instance group:
Bit0-Bit31: each bit corresponds to instance group, bit is 1, means that receives occupancy sensor signal of the instance group (bit is 1).
For example: receive occupancy sensor instance group=0x00000003, Bit0=1 & Bit1=1, means that receives occupancy sensor signal of the sensor whose instance group is 0 and 1.

DATA SHEET

DIP status:

query DIP switch status, only query and can not be changed.

DALI bus power supply status:

To switch ON/OFF the integrated DALI bus power supply, 1 means ON, 0 means OFF.

For example: change the sensitivity to 50% via broadcasting as below

START QUIESCENT MODE(broadcast)
 START QUIESCENT MODE(broadcast)
 DTR1(0x02)
 DTRO(0x02)
 ENABLE WRITE MEMORY(broadcast)
 ENABLE WRITE MEMORY(broadcast)
 WRITE MEMORY LOCATION – NO REPLY(0x55)//Unlock Lock Byte
 DTRO(0x05)
 WRITE MEMORY LOCATION – NO REPLY(0x32)//Set HF Sensitivity to 50%
 SAVE PERSISTENT VARIABLES(broadcast)
 SAVE PERSISTENT VARIABLES(broadcast)
 STOP QUIESCENT MODE(broadcast)
 STOP QUIESCENT MODE(broadcast)

WIRING MULTIPLE SENSORS

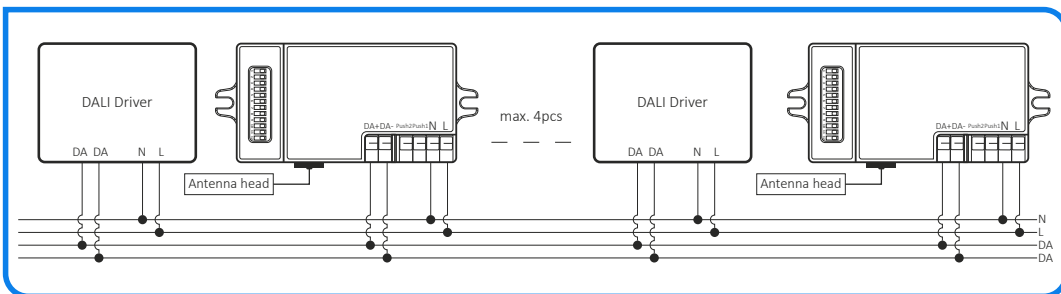

DAYLIGHT MONITORING

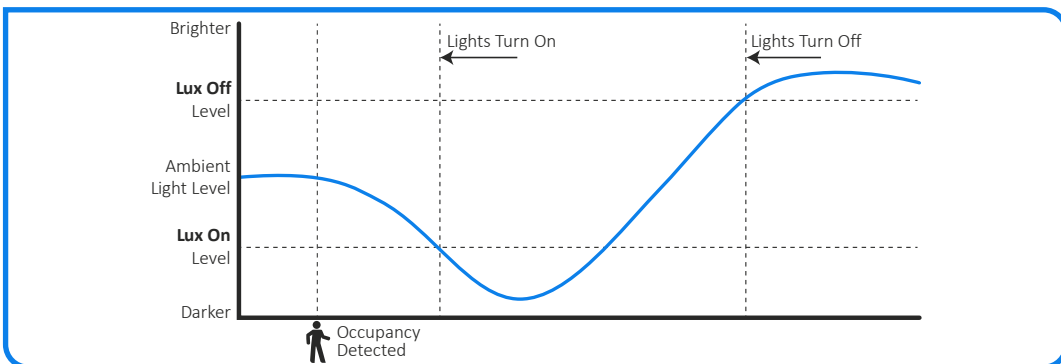

PUSH-DIM FUNCTION

On→Off: luminaire turns off immediately and cannot be triggered ON again by motion until the expiration of pre-set hold-time. After this period, the sensor goes back to normal sensor mode.

Off→On: the light turns on and goes to sensor mode. In some applications the user may not want to have a sensor automatically switch on the light, the sensor will be activated only on the manual Off→On press

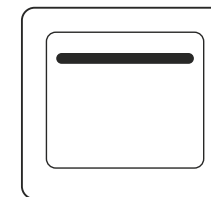

Short push (<1s)
on/off function

Long push (>1s)
adjust the target lux level by turning the light up or down.

DIP SWITCH SETTINGS

This sensor can be set up with dip switches found on the sensor. Each section controls different settings depending on the combination of switches.

Graphic to the right displays the full row of dip switches and which position indicates on or off.

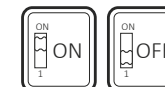
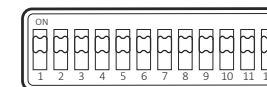

Sensitivity - Switch 1 / 2

The sensitivity can be adjusted between 25% (low sensitivity) and 100% (high sensitivity)

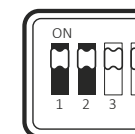

1	2	Sensitivity
On	On	100%
On	Off	75%
Off	On	50%
Off	Off	25%

Hold Time - Switch 3 / 4 / 5

The sensor will continue to provide power for a duration of time after the last motion was detected.

If any motion is detected within the set duration time the sensor will reset the timer.

This duration can be adjusted from 30 seconds up to 30 minutes.

**Test Mode: When hold-time is set at 3s, the sensor enters test mode in order to select the desired detection range/sensitivity. In this mode the daylight sensors are disabled so when there is no motion the luminaire stays off. When there is motion detected the sensor cycles 3s on and 2s off.*



3	4	5	Hold Time
On	On	On	T3s*
On	On	Off	30s
On	Off	Off	90s
Off	On	Off	5min
Off	Off	On	10min
Off	Off	Off	30min

Lux Control - Switch 6 / 7

The Sensor includes a photocell which can be used to limit the operation depending on the ambient light level.

When set to 100 lux the sensor will only operate during the hours of darkness.

When set to disable the sensor will operate regardless of the ambient light levels.



6	7	Lux
On	On	Disable
On	Off	50lux
Off	On	10lux
Off	Off	2lux

Stand-by period - Switch 8 / 9 / 10

This is the time period that the luminaire remains at a low light level before it is completely switched off in the long absence of detected motion.

+∞ = bi-level dimming control - luminaire always on.



8	9	10	Stand-by
On	On	On	10s
On	On	Off	5min
On	Off	Off	10min
Off	On	Off	30min
Off	Off	On	1h
Off	Off	Off	+∞

Stand-by dimming level - Switch 11 / 12

This is the desired dimmed low light level after the hold-time in the absence of detected motion.

*0% = on/off control.

10% Vdim = 1.5Vdc

30% Vdim = 3.0Vdc

50% Vdim = 5.0Vdc

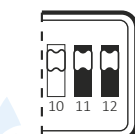

11	12	Dim Level
On	On	0%
On	Off	10%
Off	On	30%
Off	Off	50%

DETACHED SENSOR ANTENNAS

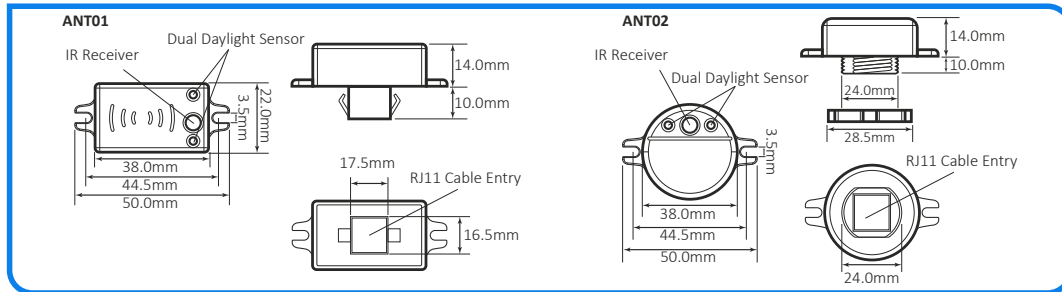

ANT01: Mounting hole size 21 x 17mm (L x W)

ANT02: Mounting hole size \varnothing 25mm

REMOTE SETTINGS

The mated remote control for this model is REM-S22.

DALI-2 & D4i standards

EN62386-101 Ed.2

EN62386-103 Ed.2

EN62386-351 Type A

