

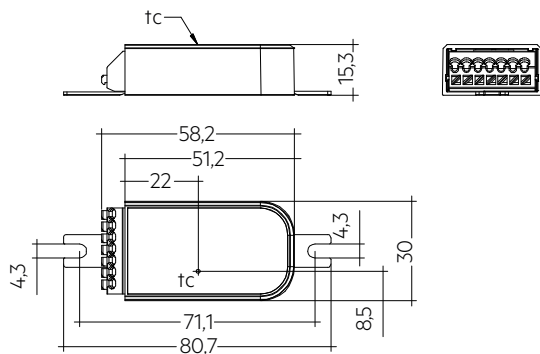

**Wireless module Passive MTR**

Matter wireless module



**Ordering data**

Type	Article number	Packaging, carton	Weight per pc.
Wireless module passive MTR	28004483	60 pc(s).	0.017 kg

**Technical data**

Supply voltage DC	9.5 – 22.5 V
Current consumption of DALI	4 mA (30 mA at start)
Max. DALI bus current	250 mA
Typ. power consumption on stand-by	< 0.09 W
Input	4 momentary-action switches
Max. cable length push button	5 m at 0.2-1.5 mm <sup>2</sup>
Radio transceiver operating frequencies	2.4 – 2.483 GHz
Max. output power radio transceiver (E.I. R.P.) <sup>①</sup>	< + 20 dBm
Output	Broadcast, DT6, DALI (compatible)
Starting time	≤ 2 s
Max. casing temperature tc	75 °C
Ambient temperature ta	-20 ... +70 °C
Storage temperature ts	-25 ... +75 °C
Lifetime	up to 50,000 h
Guarantee (conditions at www.tridonic.com)	5 Year(s)
Dimensions L x W x H <sup>②</sup>	80.7 x 30 x 15.3 mm
Type of protection	IP20

**Approval marks**



**Standards**

EN 55015, EN 55022, EN 55032, EN 61347-1, EN 61347-2-11, EN 61547, EN 18031-1, ETSI EN 300 328, ETSI EN 301 489-1, ETSI EN 301 489-17

① E.I.R.P.: Equivalent Isotropically Radiated Power.

② Screw fixings can be removed.

## 1. Standards

EN 55015  
 EN 55022  
 EN 55032  
 EN 61347-1  
 EN 61347-2-11  
 EN 61547  
 EN 18031-1  
 ETSI EN 300 328  
 ETSI EN 301 489-1  
 ETSI EN 301 489-17

### 1.1 Glow wire test

according to EN 61347-2-11 with increased temperature of 850 °C passed.

## 2. Common

### 2.1 Description

The Wireless Module Passive MTR is a Matter-capable DALI controller with 4 freely configurable push-button inputs. The module is supplied via the DALI bus, an additional mains supply is not required.

Connection of one or more DALI drivers to the module is possible (Broadcast DT6). The number depends on the DALI power supply used.

The Matter-enabled products from Tridonic communicate via IPv6 thread network and require a thread border router (e.g. Apple HomePod mini or Google Nest Hub).

### 2.2 Operation

Matter products from Tridonic are compatible with the Matter ecosystem of other manufacturers.

The product functions depend on the Matter ecosystem used. Multiple devices automatically form a threaded mesh network.

Radio-based Matter products have an integrated 2.4 GHz antenna. To achieve optimum RF performance when installing the module in a luminaire, follow the instructions in chapter 5.4 Placement.

### 2.3 Commissioning

When a Matter device is not yet commissioned, it will send out BLE (Bluetooth Low Energy) handshake communication for 15 min. It's only possible to pair the device in this period of time, afterwards a power cycle is necessary.

Also of importance:

- Network is up and running
- Thread border router compatible with the Matter ecosystem is available and in the network
- Minimum requirements:  
 Android / Google: Android O (8.1, API level 27) or newer  
 iOS / Apple: iOS version 16.x
- Matter ready devices



During commissioning and use of the product, do not enter any sensitive personal information or confidential personal information.

## 3. Thermal details and lifetime

### 3.1 Expected lifetime

Expected lifetime				
Type	t <sub>a</sub>	75 °C	70 °C	60 °C
Wireless Module Passive MTR	t <sub>c</sub>	75 °C	70 °C	60 °C
	Lifetime	38,000 h	50,000 h	100,000 h

The device is designed for a lifetime stated above under reference conditions and with a failure probability of less than 10 %.

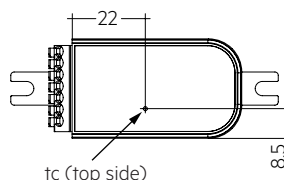

## 4. Interfaces / communication

### 4.1 DALI output

The Wireless Module Passive MTR draws its operating power directly from the DALI bus. For this reason, it is important to make sure that the DALI bus is externally powered.

If the module is connected to a DALI device without an internal power supply, an external power supply must be used.

### 4.2 Push-button input

4 independent push-buttons can be connected to each of the four input terminals. The „COM“ terminal is shared by all four push-buttons. The max. cable length between push-button and terminal is 5 m.

With the push-button inputs it is possible to control individual luminaires of a Matter network or the whole network (depending on the functionality of the Matter ecosystem).

## 5. Installation / wiring

### 5.1 Wiring diagram with external PS

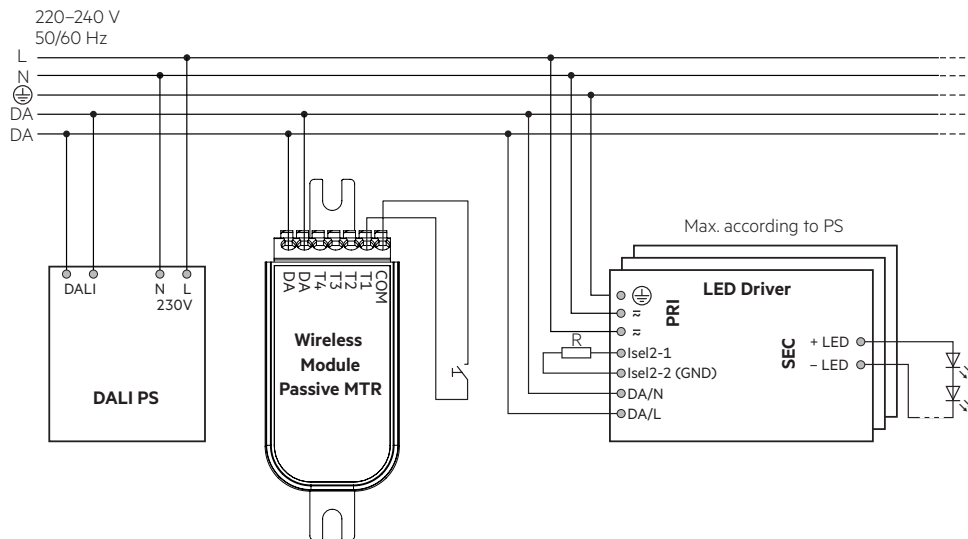

### 5.2 Wiring diagram with integrated DALI PS

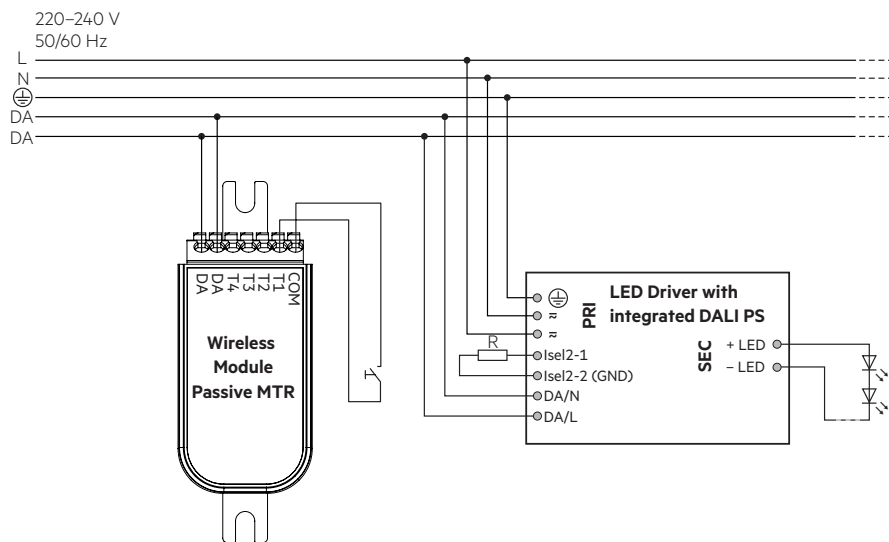

### 5.3 Wiring type and cross section

For wiring use stranded wire with ferrules or solid wire from 0.2–1.5 mm<sup>2</sup> (16–24 AWG).

Strip 8.5–9.5 mm of insulation from the cables to ensure perfect operation of the push-wire terminals.

Use one wire for each terminal connector only.

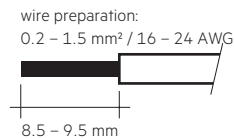

### 5.4 Placement

Wireless Module Passive MTR devices have an integrated antenna for easy integration. In order to maximize the range in every direction some design guidelines should be taken into consideration when mounting the device.

The antenna is located at the end of the enclosure.

When the device is mounted on a metal plate (e.g. frame of a luminaire), it may efficiently block the radio frequency signal. In this case, a cut-out underneath the antenna may be needed for the RF signal to exit the structure. The cut-out area should be as large as possible. Also the device should be placed as far away from any vertical metal structures as possible.



■ Antenna location



The range of the communication signal is depending on the environment e.g. luminaire, construction of the building, furnitures or humans and needs to be tested and approved in the installation.



To ensure a good radio connection, do not cover the Matter device completely with metal!

### 5.5 Installation note

Max. torque at screw fixing: 0.4 Nm / M3.

### 5.6 QR code

The unit contains 2 QR codes that are identical. One is permanently attached to the unit and the second is to be torn off and then stuck on the luminaire or stored in the commissioning documentation.



These QR codes contain device-specific data that is required to commission the Matter luminaire. Without this, it is not possible to commission a Matter luminaire.

The QR code that is placed on the luminaire should be easy for the commissioner to reach and scan, but not visible to everyone!  
If this is not possible, collect and keep the QR code stickers after commissioning.

Be sure to inform the end customer of the consequences if they are lost. With the QR code it is possible to commission the unit to a network. The QR code represents access to the network itself!

## 6. Restore factory defaults

To restore the factory settings, the module must be switched on and off in the following sequence.

If the sequence was entered correctly, the luminaire (driver) flashes 2 times.

Stage	Duration	State
1	< 5 s	ON
2	>30 s	OFF
3	5 – 15 s	ON
4	>30 s	OFF
5	< 5 s	ON
6	>30 s	OFF
7	< 5 s	ON
8	>30 s	OFF
9	permanent	ON



## 7. Miscellaneous

### 7.1 Disposal of equipment



Return old devices in accordance with the WEEE directive to suitable recycling facilities.

### 7.2 Conditions of use and storage

Humidity: 5% up to max. 85%, not condensed

Storage temperature: -25 °C up to max. +75 °C

The devices have to be acclimatised to the specified temperature range (ta) before they can be operated.

### 7.3 Matter certified

The device is a Matter certified device and listed in the Matter product database.

There are different ecosystems available in the market.

When selecting an ecosystem, make sure with the owner of the ecosystem that all the functionalities are available and usable.

Functionalities should be tested in advance.

The product functions depend on the Matter ecosystem used.

The Connectivity Standard Alliance (CSA) offers the Certification Transfer Program for re-branding/white labeling while maintaining the Certified status of those products.

To guarantee compliance while integrating these devices into luminaires, it is recommended to verify any additional requirements with the Connectivity Standards Alliance and the Transfer Program:

<https://csa-iot.org/certification/transfer-program/>

### 7.4 Use of Bluetooth technology

Use of Bluetooth technology: During initial phase of commissioning, the product communicates via Bluetooth technology.

### 7.5 Additional information

The Bluetooth® word mark and logos are registered trademarks owned by the Bluetooth SIG, Inc. and any use of such marks by Zumtobel Group AG is under license.

Tridonic GmbH & Co. KG is a subsidiary of Zumtobel Group AG.

Additional technical information at [www.tridonic.com](http://www.tridonic.com) → Technical Data

Lifetime declarations are informative and represent no warranty claim. No warranty if device was opened.