

Wireless module SR MTR

Matter wireless module

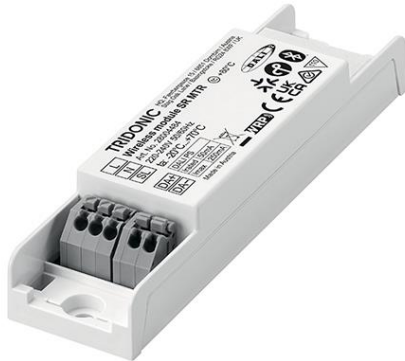

Product description

- _ Matter certified device
- _ Communication via an IPv6 Thread Network
- _ Thread Border Router is required (e.g. Apple HomePod mini or Google NestHub)
- _ Can be either used build-in or independent with clip-on strain-relief (see accessory)
- _ Optional strain-relief set for independent applications (see accessory)
- _ Digital output: DALI (Broadcast DT6)
- _ Integrated 50 mA DALI power supply
- _ Independent mains operated push-button input for free configuration
- _ Wireless firmware updates possible
- _ 5 years guarantee (conditions at <https://www.tridonic.com/en/int/services/manufacture-guarantee-conditions>)
- _ We will provide security updates for the next five years after the date of purchase of this product

Website

<http://www.tridonic.com/28004484>



Wireless module SR MTR

Matter wireless module

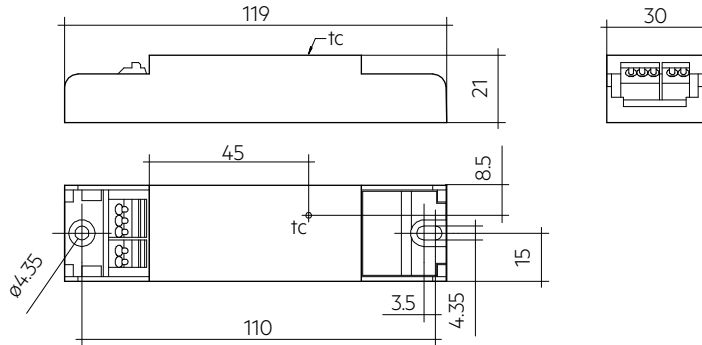

Ordering data

Type	Article number	Packaging, carton	Weight per pc.
Wireless module SR MTR	28004484	10 pc(s).	0.036 kg

Technical data

Rated supply voltage	220 – 240 V
Mains frequency	50 / 60 Hz
Max. mains current	18 mA
Typ. power consumption on stand-by	< 0.5 W
Input	1 push-button (mains operated)
Radio transceiver operating frequencies	2.4 – 2.483 GHz
Max. output power radio transceiver (E.I. R.P.) ^①	< + 20 dBm
Output	Broadcast, DT6, DALI (compatible)
Guaranteed output current, DALI ^②	50 mA
Max. output current, DALI	250 mA
Max. DALI wiring length	300 m at 1.5 mm ²
Starting time	≤ 2 s
Max. casing temperature tc	80 °C
Ambient temperature ta	-20 ... +70 °C
Storage temperature ts	-25 ... +75 °C
Lifetime	up to 50,000 h
Guarantee (conditions at www.tridonic.com)	5 Year(s)
Dimensions L x W x H	119 x 30 x 21 mm
Type of protection	IP20
Protection class	I (II with strain relief)

Approval marks



Standards

EN 55015, EN 55022, EN 55032, EN 61347-1, EN 61347-2-11, EN 61547, EN 18031-1, ETSI EN 300 328, ETSI EN 301 489-1, ETSI EN 301 489-17

① E.I.R.P.: Equivalent Isotropically Radiated Power.

② Max. 25 loads.

Strain-relief

Accessory



Product description

- _ Strain relief for up to 3 cables suitable for cable with diameter from 2.5 up to 9 mm
- _ A: 2.5 – 5 mm diameter
- _ B: 5 – 9 mm diameter
- _ C: 5 – 9 mm diameter
- _ Optional strain-relief for independent applications
- _ Transforms the unit into a full Class II compatible unit (e.g. for ceiling installation)
- _ Includes 1 piece strain-relief
- _ 5 years guarantee (conditions at <https://www.tridonic.com/en/int/services/manufacturer-guarantee-conditions>)

Website

<http://www.tridonic.com/28005598>

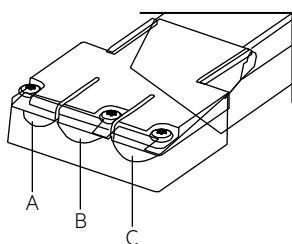
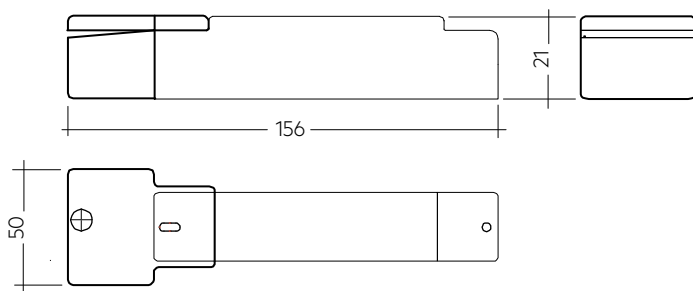

Ordering data

Type	Article number	Packaging, carton	Weight per pc.
strain-relief	28005598	10 pc(s).	0.03 kg

1. Standards

EN 55015
 EN 55022
 EN 55032
 EN 61347-1
 EN 61347-2-11
 EN 61547
 EN 18031-1
 ETSI EN 300 328
 ETSI EN 301 489-1
 ETSI EN 301 489-17

1.1 Glow wire test

according to EN 61347-2-11 with increased temperature of 850 °C passed.

2. Common

2.1 Description

The Wireless Module SR MTR is a bluetooth DALI controller with a freely configurable push-button input and has an integrated DALI power supply, therefore no external DALI power supply is necessary. The device is designed to be used in a luminaire, but with the optional strain relief set it can be also safely used in e.g. ceiling installations.

Connection of one or more DALI drivers to the module is possible (Broadcast DT6). Max. 25 drivers can be connected.

The Matter-enabled products from Tridonic communicate via IPv6 thread network and require a thread border router (e.g. Apple HomePod mini or Google Nest Hub).

2.2 Operation

Matter products from Tridonic are compatible with the Matter ecosystem of other manufacturers.

The product functions depend on the Matter ecosystem used. Multiple devices automatically form a threaded mesh network.

Radio-based Matter products have an integrated 2.4 GHz antenna. To achieve optimum RF performance when installing the module in a luminaire, follow the instructions in chapter 5.4 Placement.

2.3 Commissioning

When a Matter device is not yet commissioned, it will send out BLE (Bluetooth Low Energy) handshake communication for 15 min. It's only possible to pair the device in this period of time, afterwards a power cycle is necessary.

Also of importance:

- Network is up and running
- Thread border router compatible with the Matter ecosystem is available and in the network
- Minimum requirements:
 Android / Google: Android O (8.1, API level 27) or newer
 iOS / Apple: iOS version 16.x
- Matter ready devices



During commissioning and use of the product, do not enter any sensitive personal information or confidential personal information.

3. Thermal details and lifetime

3.1 Expected lifetime

Expected lifetime				
Type	ta	75 °C	70 °C	60 °C
Wireless Module SR MTR	tc	80 °C	76 °C	66 °C
	Lifetime	35,000 h	50,000 h	100,000 h

The device is designed for a lifetime stated above under reference conditions and with a failure probability of less than 10 %.

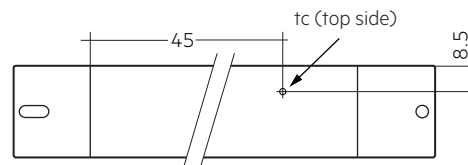

4. Interfaces / communication

4.1 DALI output

The Wireless Module SR MTR has an integrated DALI power supply. A maximum of 25 drivers can be connected to this interface.



Before connecting the Wireless Module SR MTR to a DALI line, please make sure that no other DALI power supply (including drivers with integrated PS) is powering the bus.

4.2 Push-button input

An independent push-button can be connected to the input terminals of the Wireless Module SR MTR.

The max. cable length between push-button and terminal is 5 m.

With the push-button input it is possible to control individual luminaires of a Matter network or the whole network (depending on the functionality of the Matter ecosystem).

5. Installation / wiring

5.1 Wiring diagram DALI (compatible mode)

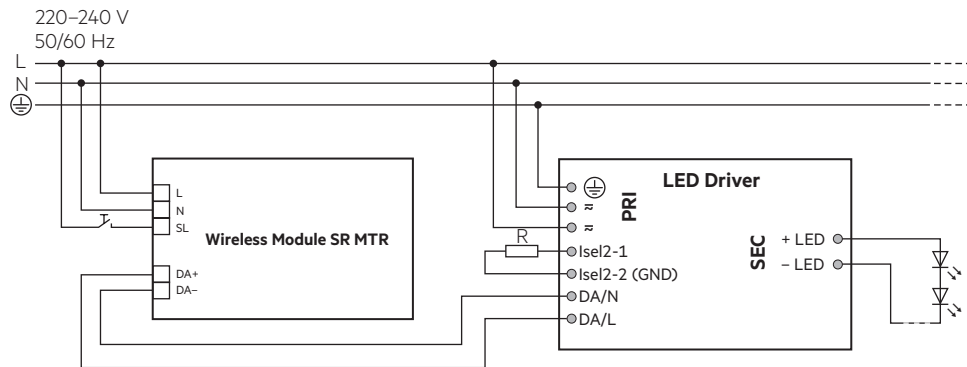

5.2 Wiring diagram as sensor module for wireless switching

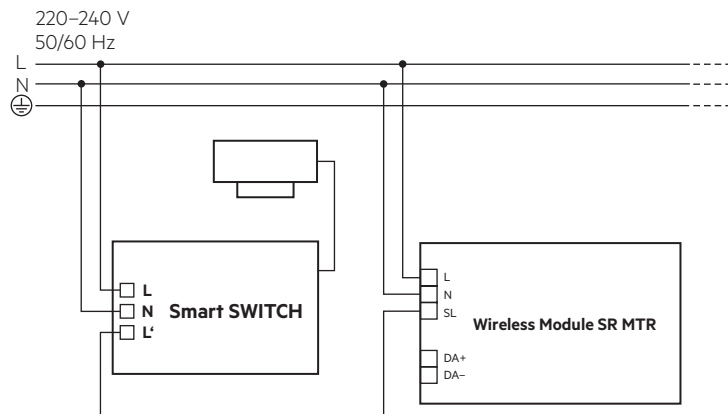

5.3 Wiring type and cross section

For wiring use stranded wire with ferrules or solid wire from 0.2–1.5 mm² (16–24 AWG).

Strip 8.5–9.5 mm of insulation from the cables to ensure perfect operation of the push-wire terminals.

Use one wire for each terminal connector only.

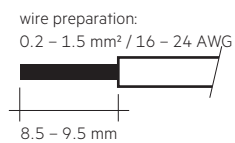

5.4 Placement

Wireless Module SR MTR has an integrated antenna for easy integration. In order to maximize the range in every direction some design guidelines should be taken into consideration when mounting the device.

The antenna is located at the end of the enclosure. It is on the top side of the internal PCB (Printed Circuit Board).

When the device is mounted on a metal plate (e.g. frame of a luminaire), it may efficiently block the radio frequency signal. In this case, a cut-out underneath the antenna may be needed for the RF signal to exit the structure. The cut-out area should be as large as possible. Also the device should be placed as far away from any vertical metal structures as possible.



■ Antenna location



The range of the communication signal is depending on the environment e.g. luminaire, construction of the building, furnitures or humans and needs to be tested and approved in the installation.



To ensure a good radio connection, do not cover the Matter device completely with metal!

5.5 Installation note

Max. torque at screw fixing: 0.4 Nm / M3.

Dry, acidfree, oilfree, fatfree. It is not allowed to exceed the maximum ambient temperature (t_a) stated on the device. Minimum distances stated below are recommendations and depend on the actual luminaire.

Is not suitable for fixing in corner.

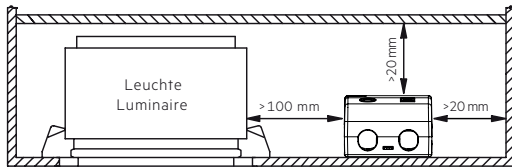

Device not suitable for covering with thermally insulating material according to IEC 60598-1 Ed.9

5.6 QR code

The unit contains 2 QR codes that are identical. One is permanently attached to the unit and the second is to be torn off and then stuck on the luminaire or stored in the commissioning documentation.



These QR codes contain device-specific data that is required to commission the Matter luminaire. Without this, it is not possible to commission a Matter luminaire.

The QR code that is placed on the luminaire should be easy for the commissioner to reach and scan, but not visible to everyone! If this is not possible, collect and keep the QR code stickers after commissioning.

Be sure to inform the end customer of the consequences if they are lost. With the QR code it is possible to commission the unit to a network. The QR code represents access to the network itself!

6. Restore factory defaults

To restore the factory settings, the module must be switched on and off in the following sequence.

If the sequence was entered correctly, the luminaire (driver) flashes 2 times.

Stage	Duration	State
1	< 5 s	ON
2	>30 s	OFF
3	5 – 15 s	ON
4	>30 s	OFF
5	< 5 s	ON
6	>30 s	OFF
7	< 5 s	ON
8	>30 s	OFF
9	permanent	ON



7. Miscellaneous

7.1 Disposal of equipment



Return old devices in accordance with the WEEE directive to suitable recycling facilities.

7.2 Conditions of use and storage

Environmental conditions: 5% up to max. 85%,
not condensed

Storage temperature: -25 °C up to max. +75 °C

The devices have to be acclimatised to the specified temperature range (ta) before they can be operated.

7.3 Matter certified

The device is a Matter certified device and listed in the Matter product database.

There are different ecosystems available in the market.

When selecting an ecosystem, make sure with the owner of the ecosystem that all the functionalities are available and usable.

Functionalities should be tested in advance.

The product functions depend on the Matter ecosystem used.

The Connectivity Standard Alliance (CSA) offers the Certification Transfer Program for re-branding/white labeling while maintaining the Certified status of those products.

To guarantee compliance while integrating these devices into luminaires, it is recommended to verify any additional requirements with the Connectivity Standards Alliance and the Transfer Program:

<https://csa-iot.org/certification/transfer-program/>

7.4 Use of Bluetooth technology

Use of Bluetooth technology: During initial phase of commissioning, the product communicates via Bluetooth technology.

7.5 Additional information

The Bluetooth® word mark and logos are registered trademarks owned by the Bluetooth SIG, Inc. and any use of such marks by Zumtobel Group AG is under license.

Tridonic GmbH & Co. KG is a subsidiary of Zumtobel Group AG.

Additional technical information at www.tridonic.com → Technical Data

Lifetime declarations are informative and represent no warranty claim.

No warranty if device was opened.