

**smartSWITCH 5DP 14f**

Automatic switching based on motion and light level

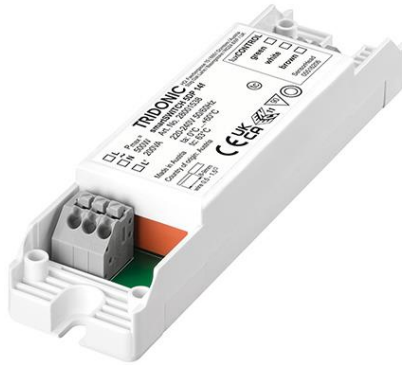

**Product description**

- \_ Motion detector for luminaire installation
- \_ For automatic on/off switching of luminaires with electronic ballasts and LED drivers
- \_ Bright-out function: luminaire is not switched on if there is adequate brightness
- \_ Maximum of 1 sensor possible
- \_ Low profile casing (21 x 30 mm)
- \_ For a maximum of 2 LED drivers
- \_ Delay time and light value for the bright-out function can be set via 2 potentiometers

**Website**

<http://www.tridonic.com/28001538>



**smartSWITCH 5DP 14f**

Automatic switching based on motion and light level

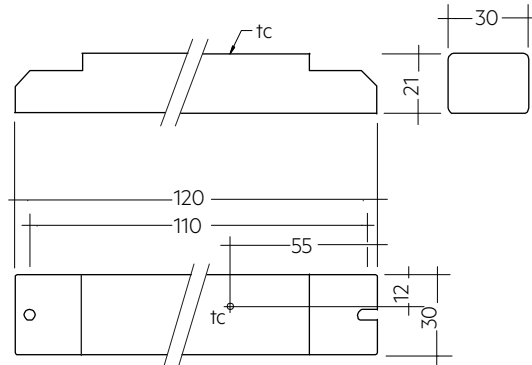
**Ordering data**

Type <sup>®</sup>	Article number	Packaging, carton	Weight per pc.
smartSWITCH 5DP 14f	28001538	10 pc(s).	0.057 kg

**Technical data**

Sensor type	PIR sensor
Rated supply voltage	220 – 240 V
Max. input current (at 230 V, 50 Hz, full load)	0.02 A
Mains frequency	50 / 60 Hz
Power (output on)	0.6 W
Output, standby (output off)	0.35 W
Max. smartSWITCH sensors	1
Sensor cable length	0.54 m
Max. number of switched drivers	2
Max. Inrush current of the load (peak / duration)	55 A / 400 $\mu$ s
Typ. number of switching cycles <sup>①</sup>	50,000
Max. resistive load	500 W
Max. inductive / capacitive load	200 VA
tc point	63 °C
Ambient temperature $t_a$	0 ... +60 °C
Type of protection	IP20
Lifetime	up to 50,000 h

**Approval marks****Standards**

EN 61347-1, EN 61347-2-11, EN 61000-3-2, EN 61547, EN 55015

<sup>①</sup> See data sheet 4.2 Switching cycles.

<sup>②</sup> Housing colour sensor: white, housing colour controller: grey.

## 5DPI 14f Mounting Kit

Accessory

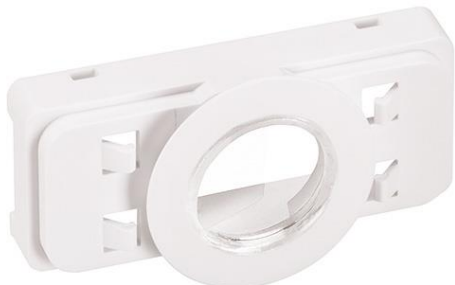
**Product description**

- \_ Mounting frame for attaching all 5DP 14f sensor directly to the luminaire housing
- \_ Optional shutter to prevent presence detection in a specific direction (for PIR sensors)
- \_ Glow wire test with 750 °C according to EN 61347-1

**Website**<http://www.tridonic.com/28001558>**Ordering data**

Type	Article number	Packaging, carton	Weight per pc.
5DPI 14f mounting kit	28001558	100 pc(s).	0.004 kg
5DPI 14f mounting kit black	28001575	100 pc(s).	0.004 kg

### 1. Standards

- EN 61347-1
- EN 61347-2-11
- EN 61000-3-2
- EN 61547
- EN 55015

### 2. Installation



- Not for use with phase cut dimmers.
- The sensor must protrude over the light sources.
- Always disconnect the power supply before installation.
- Suitable for installation only in indoor luminaires (e.g. corridors and closed parking garage) without vibration.
- An opening angle of the sensor is necessary.
- Avoid direct illumination of the light source on the sensor including housing.
- Route the sensor wires separately from the lamp and mains wires, otherwise malfunctions will occur in the lighting control system. Be sure to use shielded lamp and mains wires, if separate routing is not possible (for reasons of space).
- Be sure to install the sensor according to the installation instructions, to ensure IP protection.
- Sensor head is not UV resistant.

#### 2.1 Wiring diagram

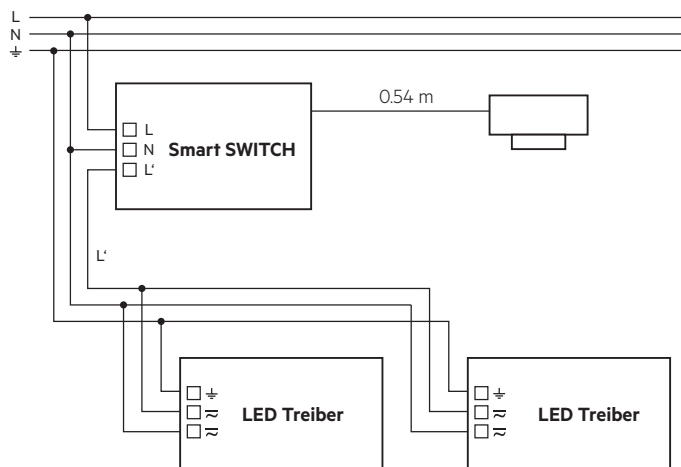

Connect max. 2 LED drivers, please note the max. load and inrush current, see page 2.

### 2.2 smartSWITCH Sensor

cable entry point on the side

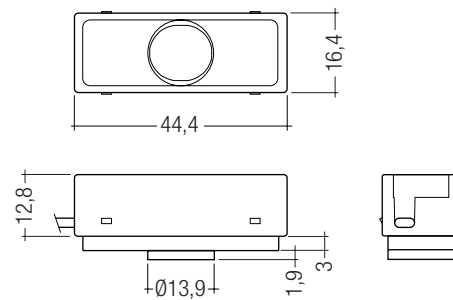
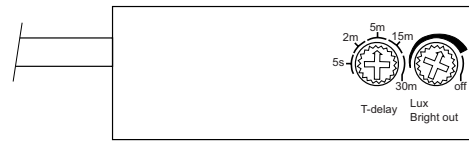

Ultra-compact luminaire mounted sensor for ambient light and detection of movement.

#### 2.3 Mounting variants luminaire housing:

Size of the sheet: 0.8 – 1.8 mm

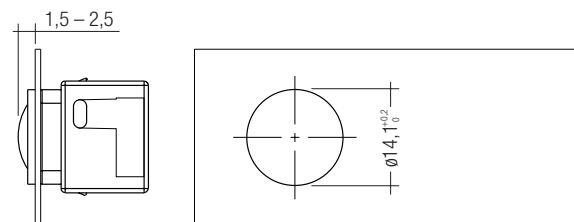

Size of the sheet: 0.8 – 3.0 mm

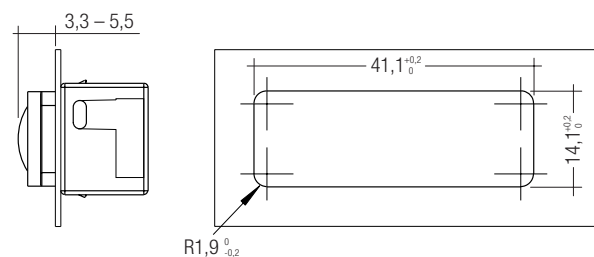

**2.4 Mounting in luminaire housing with Mounting Kit:**

Size of the sheet: 0.8 – 2.0 mm

Dimension drawing for needed mounting opening

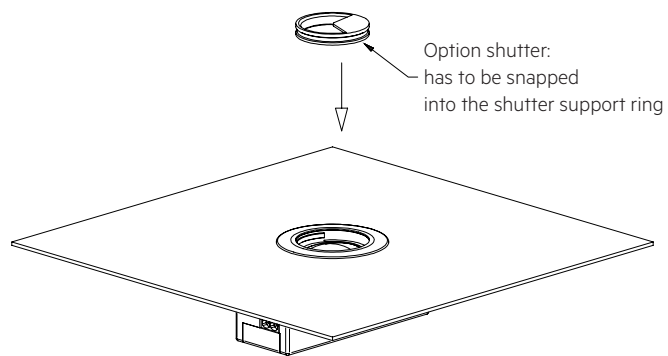
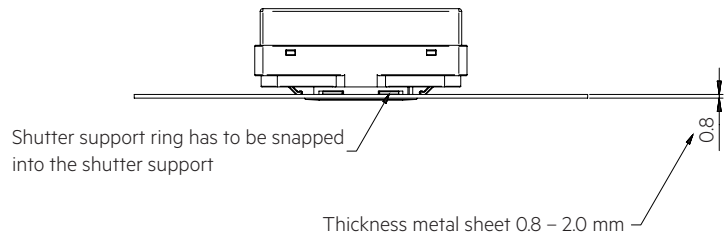
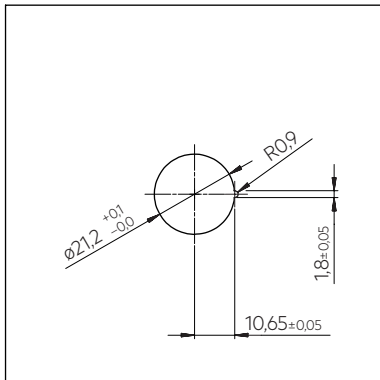

**2.5 Mounting Kit mounting**

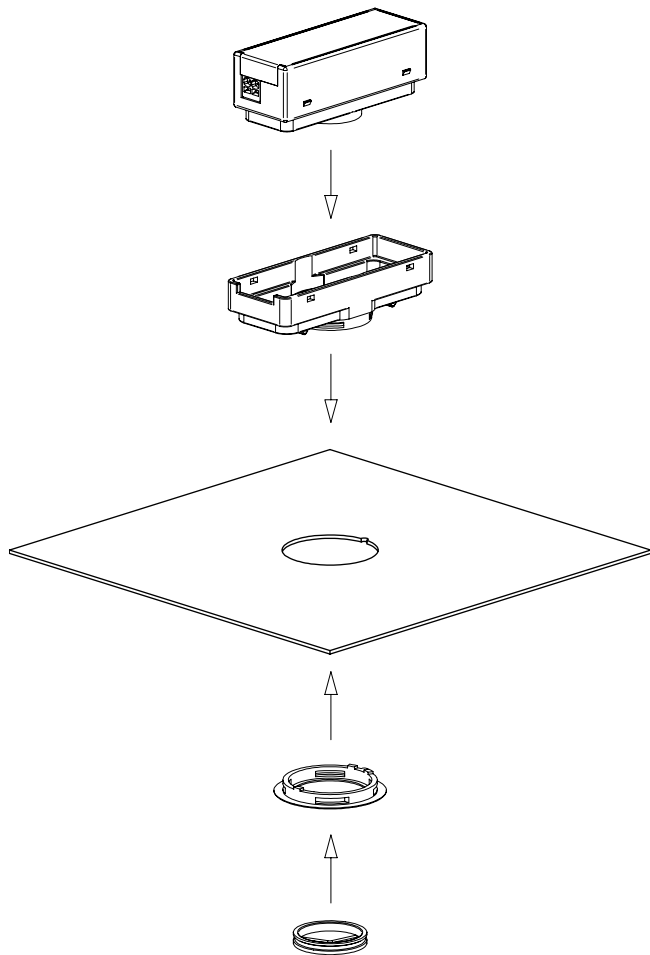

**2.6 Mounting Kit Shutter**

Area which is masked by the shutter.

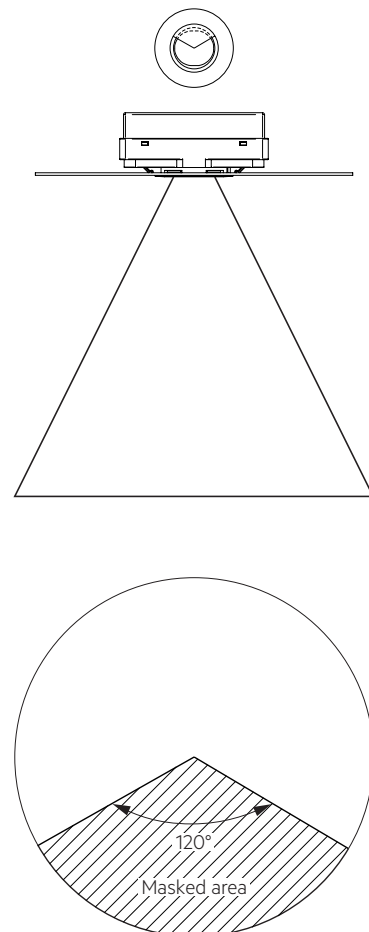

### 2.7 Mounting in class II luminaire

The Sensor provides basic insulation as required by IEC 62386-101 and defined in IEC 61347-1.

If the sensor is built in to a class II luminaire, which has to provide double or reinforced insulation, it has to be considered that the Sensor is not a class II device. Still the Sensor can be used for such projects as the front of the sensor is tested to fulfill the class II requirements for double or reinforced insulation.

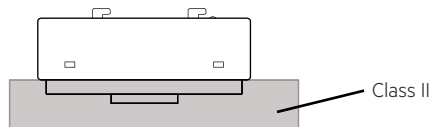

### 3. Sensor functions

#### 3.1 Light level recognition area

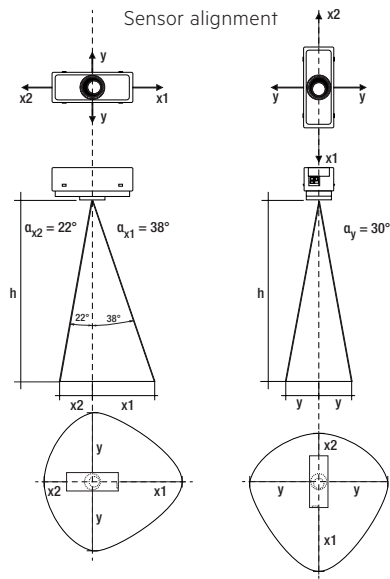

h *	x1	x2	y	d
1.7 m	1.3 m	0.7 m	1.0 m	3.0 m
2.0 m	1.6 m	0.8 m	1.2 m	3.6 m
2.3 m	1.8 m	0.9 m	1.3 m	4.1 m
2.5 m	2.0 m	1.0 m	1.4 m	4.5 m
2.7 m	2.1 m	1.1 m	1.6 m	4.9 m
3.0 m	2.3 m	1.2 m	1.7 m	5.4 m
3.5 m	2.7 m	1.4 m	2.0 m	6.3 m
4.0 m	3.1 m	1.6 m	2.3 m	7.2 m

\* The recommended maximum room height for office applications is 3 m and for corridor applications for example 4 m. Up to 2 m mounting height presence is detected and over 2 m motion is detected.

Calculation of the diameter (light area):

$$x1 = \tan(\alpha_{x1}) \times h$$

$$x2 = \tan(\alpha_{x2}) \times h$$

$$y = \tan(\alpha_y) \times h$$

Calculation of the diameter (motion area):

$$d = 2 \times \tan(0.5 \times \alpha) \times h$$

Example for light and motion detection area at height of 1.7 m:

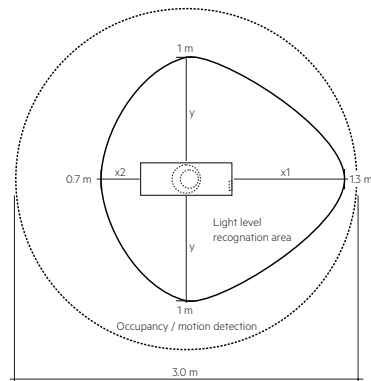

#### 3.2 Presence / motion detection

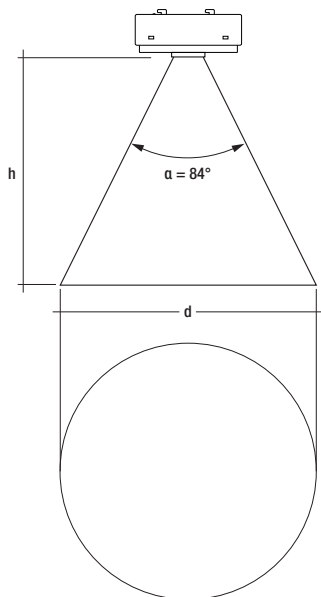

### 3.3 Adjustments

Potentiometer times = 5 s, 2 m, 5 m, 15 m, 30 m, default = 5 s  
 (Note: Only discrete steps are selectable, no intermediate values)  
 Potentiometer lux = 50 – 500 lx, default = off

Bright-out:  
 Bright-out will be activate if position off is not selected.

No adjustable parameters:  
 Switch OFF light level: 250 % of the adjustable switch ON light level  
 Bright-out delay time: 10 min.  
 Power up behavior: When power up, the smartSWITCH will switch ON

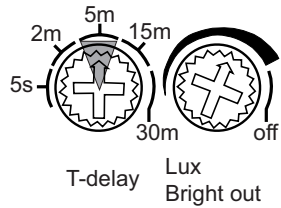

In the example above the 5 minute range is selected.

## 4. Miscellaneous

### 4.1 Disposal of equipment



Return old devices in accordance with the WEEE directive to suitable recycling facilities.

### 4.2 Additional information

Additional technical information at [www.tridonic.com](http://www.tridonic.com) → Technical Data

Guarantee conditions at [www.tridonic.com](http://www.tridonic.com) → Services

Lifetime declarations are informative and represent no warranty claim.  
 No warranty if device was opened.

### 4.3 Switching cycles

The number of switching cycles is directly related to the level and duration of the inrush current. To increase the number of cycles either LED drivers with lower inrush current (e.g. Tridonic Industry LED drivers) or an additional external relay can be used.